

FABRICATING MACHINERY INCLUDING MANUALLY
OPERATED AND HYDRAULIC TOOLS

Connecticut
PEXTO

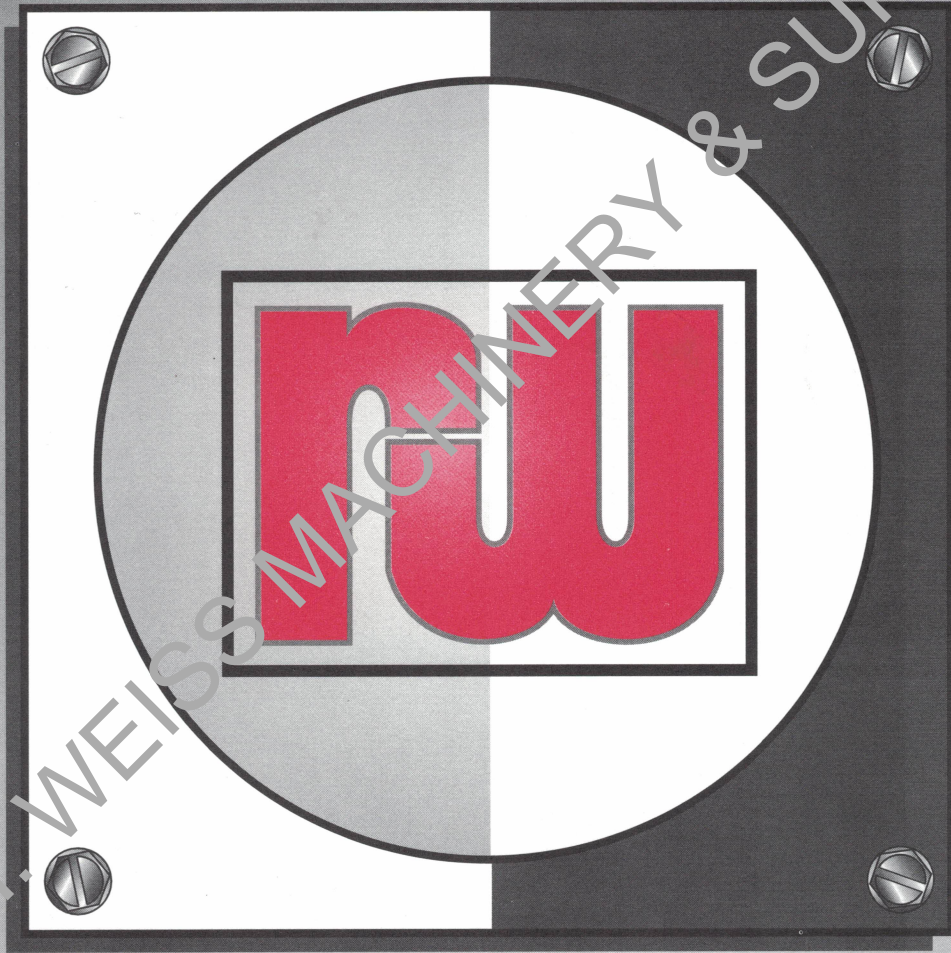

ROPER WHITNEY

CATALOG M/P/H

TABLE OF CONTENTS

NOTCHERS	4
Corner Radius Machine, 911	5
FORMERS	
Beading Machine	6
Crimping/Beading Machines	6
Combination Rotary	6
Bases	7
Roll Char/544, 622, 0617, 3617	9
Powered Beading Machine	8
ROLL BENDING MACHINE	
Manually Operated	10/14
Cheek Bender	11
SR-12 1" Roll	12
BENDING BRAKES	
PX 24	14
Heavy Duty RW	18
Auxiliary Attachments	19
Magnabend	16
Connecticut	17
Letter Forming Brake	4
SHEARS	
Ring and Circle Shears	12
Adjustable Bar Folder	13
Foot Squaring Shears	20
Hydraulic Squaring Shears	21
Mechanical Shears 10M10, 10M14	22
Hydraulic - 10 Gauge and 1/4"	23
HYDRAULIC PUNCHES	
Punch HP520	27
Power Unit HP501	27
PUNCHES AND PRESSES	
Foot Press	24
Lever Press	25
Deep Throat Mechanical Presses	26
TECHNICAL REFERENCE DATA	28

Roper Whitney hand operated notchers come in both bench style and portable hand tool styles. They provide a variety of special capabilities: notching, box forming, dovetailing, coping and corner shearing; for sheet metal, angle iron and flat stock.

Bench Notchers

No. 100 Notcher

No. PS-66 Notcher, Coper, Shear

- Hand Operated
- Bench or Floor Mounted
- Adjustable Gauge Stops
- Replaceable Blades
- Finger Guards

These handy tools, operating on heavy duty bearings, trim, notch and cope (PS-66) up to 16 gauge sheet metal. The PS-66 is somewhat more rugged in construction and can be used to make inside cuts and to shear with only one side of the blade, which is not recommended with the No. 100. Both shears have adjustable blades, duplicate scales, adjustable gauge stops, and finger guard. Both the upper and lower blades are replaceable. Box flange blades are offered in both models and each has the option of a floor mount stand.

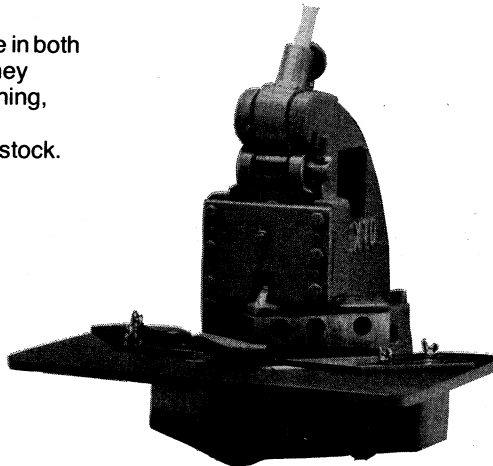

NO. PS 66

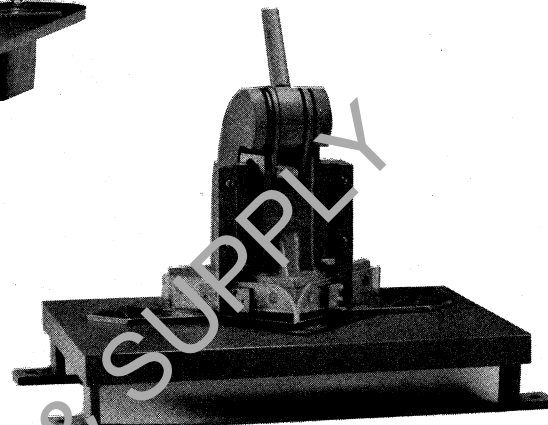

NO. 100

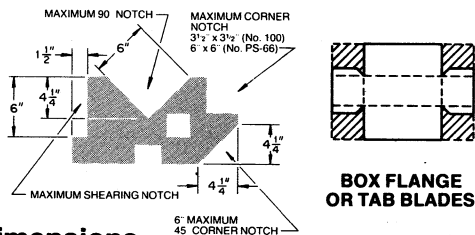

Dimensions

Reference	No. 100		No. PS-66	
	IN.	MM	IN.	MM
Tool Height (o.a.) (less handle)	11½	292	17	432
Tool Width (o.a.)	21¼	540	18	457
Tool Depth (o.a.)	12½	318	17	432
Tool Handle Length	24	610	24	608
Floor Stand Height	32	813	30	762
Floor Stand Width	24½	622	16	406
Floor Stand Depth	12	305	20	508

Ordering Guide

Description	Catalog No.		Weight (Lbs.)	
	No. 100	No. PS-66	No. 100	No. PS-66
Notcher with hi-speed blades (w/o floor stand)	145071001	145070661	110	200
Complete set hi-speed replacement blades	—Upper only	250001023	—	—
	—Lower only	250001022	—	—
Notcher with box flange blades (w/o floor stand)	145071002	145070662	110	200
Complete set* box flange replacement blades	—Upper only	250001021	—	—
	—Lower only	250001020	—	—

*Upper and lower.

Specifications

Capacity, Mild Steel	20 ga.
Max. Bending Length	12"
Slot Dimensions	See drawings
Slot Depths	3/4"
Max. Opening Between Jaws	1½"
Floor Space	24" x 29"
Overall Height	39"

NO. 99

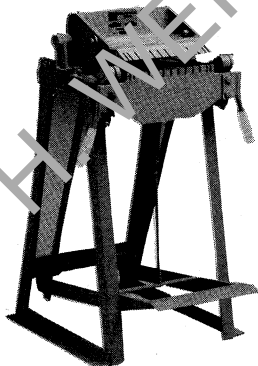

Letter Forming Brake No. 99

This unique small bending brake, with its slotted jaws and apron, is especially designed for bending sheet metal strips which have one or more bent-up edges or seams already formed; such as forming the "drum return" on metal sign letters. It may also be used for straight bending of sheet metal up to 12" wide.

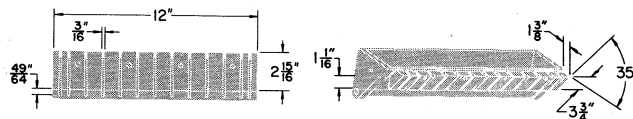
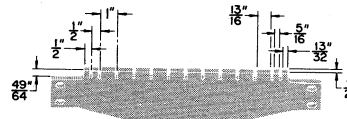

Ordering Guide

Description	Catalog No.	Weight (Lbs.)
No. 99 Letter Forming Brake	155010990	185

911 RADIUS MASTER

ROPER WHITNEY'S Radius Master is a must for every fabricating shop. It's a hydraulically operated, self contained unit for making radii in mild steel from 27 gauge up to 7 gauge without having to make blade adjustments and no setup.

The **Radius Master** comes standard with 11 radii from 1/8" to 1" - 1/8, 3/16, 1/4, 5/16, 3/8, 7/16, 1/2, 5/8, 3/4, 7/8 & 1". Special size radii may also be ordered up to 3" maximum radii.

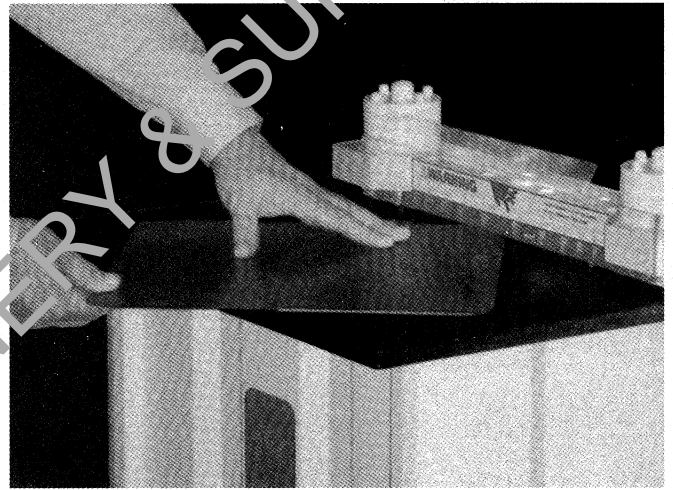

Radius Master 911

911	18811911	Radius Master with 11 radii 1/8" - 1
911	18811913	Radius Master 911 with large radii rated for 14 gauge material 1-1/4", 1-1/2", 1-3/4", 2"
911	18811912	Radius Master 911 with large metric radii 30mm, 50mm, 40mm, 35mm

Specifications: Operated on 115 volts - 1.0 amps and 80 psi shop air with safety foot switch as standard equipment.

Weight: 295 lbs.
Height: 40 inches
Length: 25 inches
Width: 20 inches

The forming machines included in this section offer a broad variety of shapes and capabilities in forming sheet metal for a combination of uses: beading, crimping, setting down, double seaming, turning, buring, wiring, elbow edging, flanging and flattening. All are precise in the job they do and are readily adaptable to job requirements. Most are portable and may be set up at the job with a clamp-on base.

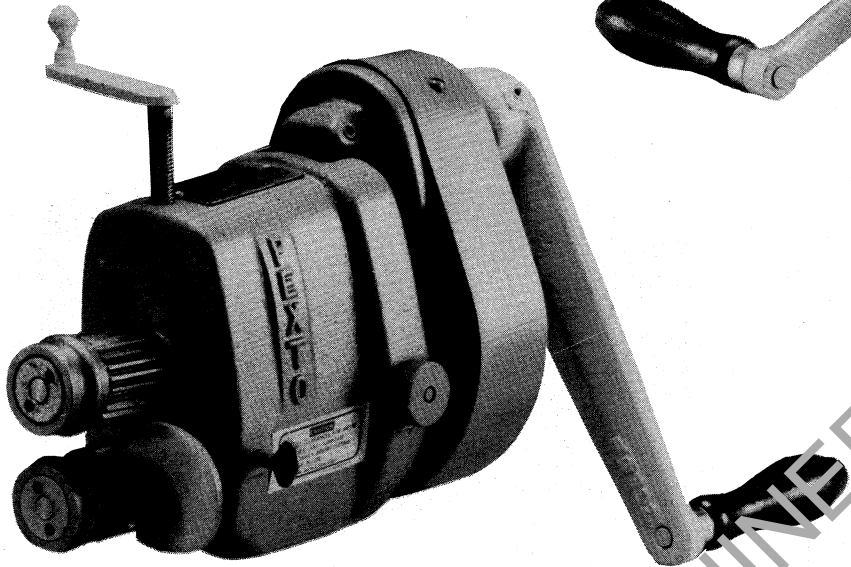

NO. 0585

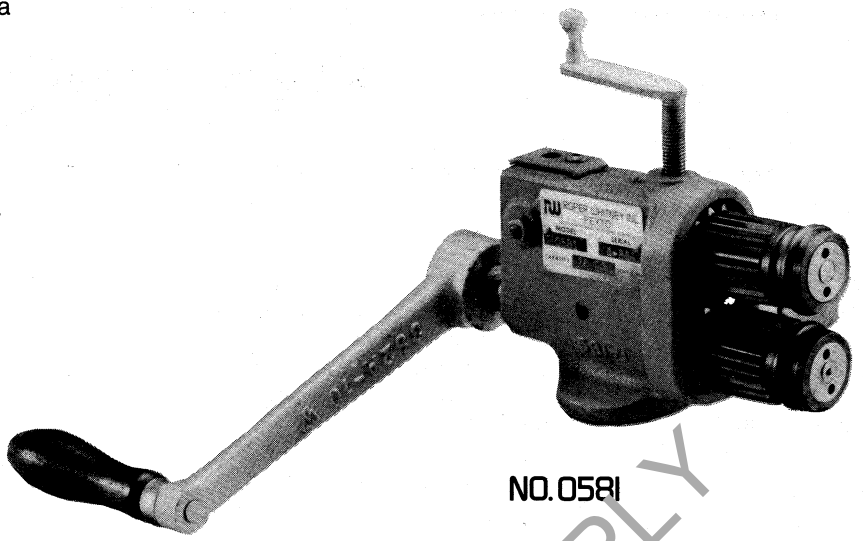

NO. 0581

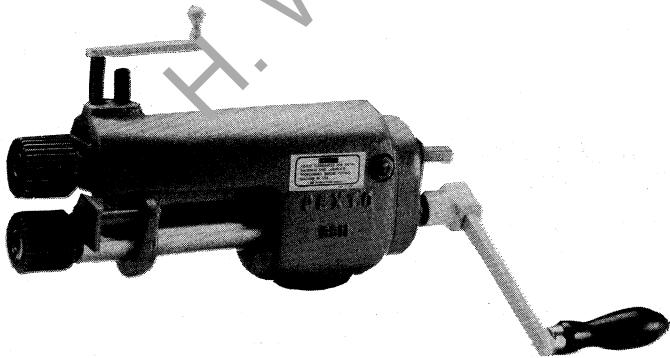

NO. 622 SERIES

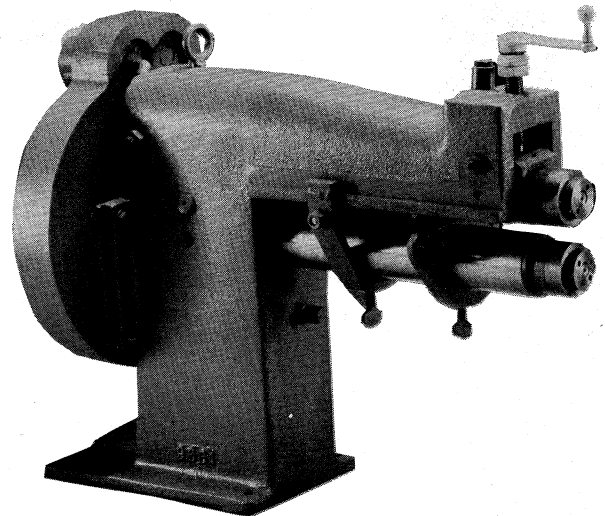

NO. 0617

NO. 0617, NO. 0581, NO. 0585, NO. 544 SERIES, NO. 622 SERIES

Beading Machine No. 0617

The No. 0617 beading machine is a deep throat (13" capacity design that is shipped with standard spacing collars and gauges for all operations except flanging. Rolls are ordered separately from the list on page 9. It will form metal up to 18 gauge.

Crimping/Beading Machines No. 0581, 0585

These machines include Ogee bead and crimping rolls to provide one pass combined crimping and beading. They are adjustable for deep or shallow beading and for "fade-away" crimping. By replacing the beading rolls with spacing collars (furnished), the machines can be used for crimping only. $\frac{3}{8}$ " and $\frac{1}{2}$ " Single Bead Rolls are available for the No. 0585 machine.

The No. 622 Series is similar to the No. 544, with the addition of a 7" deep throat for additional forming capabilities, such as furnace collar edging. The Model No. 622 includes a set of rolls (A, C, D, E and F) and gauges or may be ordered without rolls as Model No. 622LR.* A number of rolls may be ordered separately from the Roll Chart on page 9 to use with this machine.

All of the 544 Series and No. 622 Series machines include No. 975 clamp-on offset base.

Base for Forming Machines No. 975

No. 975 is a removable bench-mounted Standard Duty Offset Base.

Specifications

	No. 0617	No. 0581	No. 0585	No. 544 Ser.	No. 622 Ser.
Capacity (gauge)	18	24	20	22	24
Throat Depth (In.)	13	—	—	—	7

Ordering Guide

Description	Catalog No.	Weight (Lbs.)
No. 0617 Beading Machine	164006170	216
No. 0581 Crimping/Beading Machine including Ogee bead and crimping rolls.	164005810	30
No. 0585 Crimping/Beading Machine including Ogee bead and crimping rolls. $\frac{3}{8}$ " and $\frac{1}{2}$ " single bead rolls available separately.	164005850	51
Gauges for No. 544 Series		
Standard Gauge	259700028	—
Curved Gauge for "L" Rolls	259700029	—
Apron Gauge for #1 Rolls	259700046	—
Rolls (See Roll Chart, Page M/30)		
No. 622LR Combination Rotary Machine without rolls. Includes throat gauges and extension gauge.	164006220	45
No. 622 Combination Rotary Machine with A, C, D, E, F rolls. Includes standard ext. and throat gauges.	164006221	50
Gauges for No. 622 Series		
Standard Gauge	259200032	—
Curved Gauge	259700045	—
Extension Gauge	259700060	—
Throat Gauge	259700093	—
ROLLS (See Roll Chart, Page 5)		
No. 975 Base	239009750	11



No. 975

Beading Machine

A versatile machine designed for deep throat (up to 13") beading, crimping and other roll operations (as indicated in roll chart) on up to 18 gauge material. Back-gearred, with steel horn, bronze bushed bearing and one-piece frame. Mounted on floor stand with adjustable motor mount, "V" belt drive, and ¾ h.p. geared head motor. Unit includes gauges and spacing collars for all operations except flanging. Rolls ordered separately.

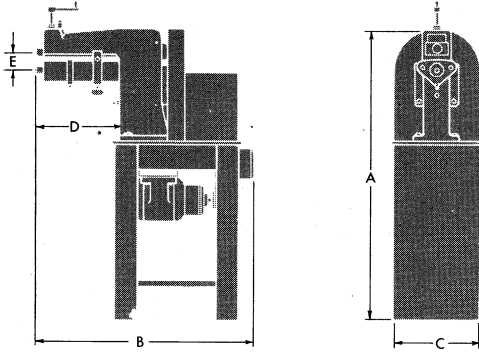

Dimensions

Reference	IN.	CM
A	52	132
B	39	99
C	14	36
D	13	33
E	3	8







Specifications

Capacity	18 ga.
Depth of throat	13 in.
Distance between centers	3 in.
Ratio gearing	3½:1
Roll speed	40 rpm
Motor (230 or 460 V, 3 ph)	¾ h.p.

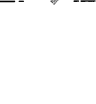
Ordering Guide

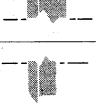
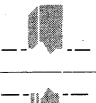
Description	Catalog No.	Weight (Lbs.)
No. 3617 Beading Machine 230V	184313617	320
No. 3617 Beading Machine 460V	184413617	320
No. 3617 Beading Machine 208V	184513617	320

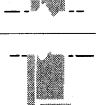
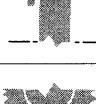
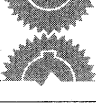

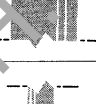
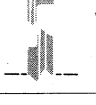
Roll Style	2" Centers					Roll Catalog No.		Gauge Required (3617)	Spacing Collar (3617)
	Roll Description	Roll Cat. Number		Gauge Req'd Series 544	Gauge Req'd Series 622				
A	 Turning	1/8"	350000001	259700028	259700032	3/16"	350000086	259700035	381700092
			350000002				350000087		
B	 Turning	3/16"	350000049	259700028	259700032	1/4"	350000088	259700035	381700092
			350000050				350000089		
C	 Burring		350000003	259700028	259700032		350000092	259700035	381700092
			350000004				350000093		
D	 Wiring		350000005	259700028	259700032		350000034	259700035	381700092
			350000006				350000035		
No. 1	 Elbow Edging		350000051	259700028 or 259700046	259700032		350000122	259700035	381700092
			350000052				350000123		
L	 Flange		350000053	259700028	259700045		350000137	CONSULT FACTORY	381700092
			350000054				350000138		
M	 Flattening		350000055	NONE	NONE		350000139	NONE	381700092
			350000056				350000140		
E	 Crimping		350000007	N/A	259700060	1/4"	350000098	259700034	381700092
			350000008				350000099		
F	 Ogee Feed	3/4"	350000009	N/A	259700093	9/16"	350000100	259700035	Not Req'd
			350000010				350000101		381700092
G	 Single Bead	1/4"	350000029	N/A	259700093	3/8"	350000013	259700035	381700092
			350000030				350000014		Not Req'd
H	 Slitting Cutters		350700068	N/A	259700032		Carbon 350700070	259700035	381700085
			350700069				High Speed 350700067		
N	 Furnace Collar Edging		350000067	N/A	259700060		350000070	259700034	381700092
			350000068				350000071		
P	 Offset		350000069	N/A	259700060		350000072	259700034	381700092
			(2 req'd)				350000073		
P	 Offset		350000076	N/A	259700060		350000074	259700034	381700092
			350000077				350000075		

NO. 383, NO. 382, NO. 381, NO. 0381, NO. 390, NO. 392, NO. 416, NO. 418

Manually Operated

Work rolls of precision turned and ground high carbon steel. 2", 2½" and 3" diameter rolls with wiring grooves and fully enclosed gear housings. 2" & 2½" dia. have two driven rolls with 3rd roll drive optional; 3" has three driven rolls. Two handles provided for 2½" & 3" sizes only. Upper roll lifts for convenient removal of workpiece. Bench mounted, with welded steel cabinet stand available. The rear rolls of No. 416 and No. 418 are provided with three full length longitudinal grooves.

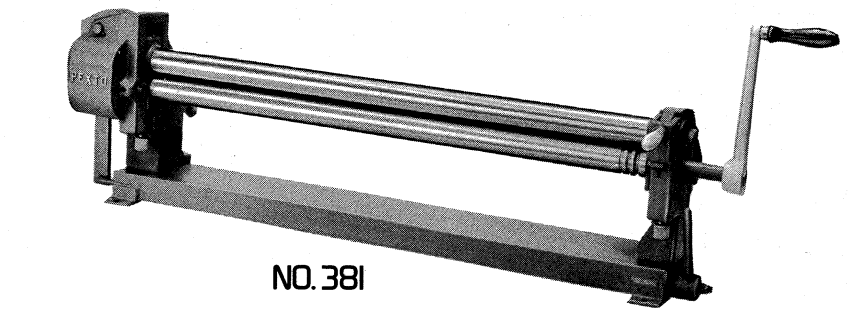

NO. 381

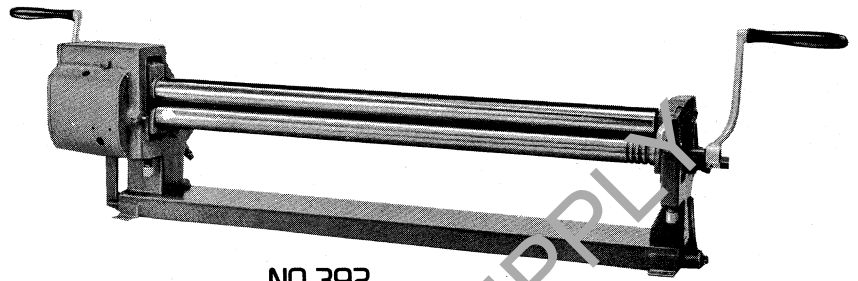

NO. 392

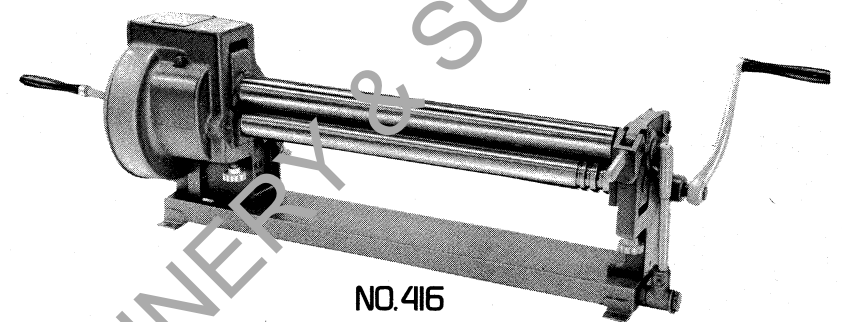

NO. 416

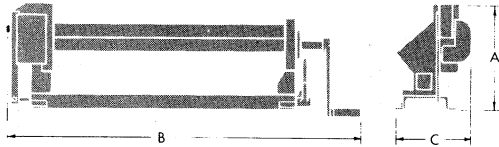

FLOOR MOUNT STAND

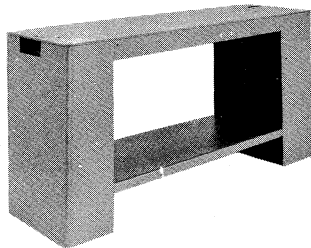

Dimensions

Reference	No. 383		No. 381		No. 0381		No. 390		No. 392		No. 416		No. 418	
	IN.	CM	IN.	CM	IN.	CM	IN.	CM	IN.	CM	IN.	CM	IN.	CM
A	15	38	15	38	15	38	17	43	17	43	19	48	19	48
B	43	109	55	140	61	155	62	157	77	196	69	175	81	206
C	11	28	11	28	11	28	18	46	18	46	19	48	19	48

Specifications

Characteristics	No. 383	No. 381	No. 0381	No. 390	No. 392	No. 416	No. 418
Capacity mild steel (ga.)	20	22	24	16-18	20-22	16	18
Max. sheet length (in.)	24	36	42	36	48	36	48
Roll diameter (in.)	2	2	2	2½	2½	3	3
Gearing ratio	DIRECT DRIVE						
Wiring grooves (in.)	3/16, ¼, 5/16	3/16, ¼, 5/16	3/16, ¼, 5/16	¼, 9/32, 5/16, 3/8	¼, 9/32, 5/16, 3/8	3/8, ½, 5/8	3/8, ½, 5/8

Ordering Guide

Description	Catalog No.	Weight (Lbs.)	Description	Catalog No.	Weight (Lbs.)
No. 383 Roll Bending Machine	167070383	197	No. 0381 Roll Bending Machine	167071381	265
Floor mount stand	239006006	128	Floor mount stand	239006007	222
			No. 390 Roll Bending Machine	167070390	457
			No. 392 Roll Bending Machine	167070392	540
No. 381 Roll Bending Machine	167070381	245	No. 416 Roll Bending Machine	167070416	720
Floor mount stand	239006007	165	No. 418 Roll Bending Machine	167070418	793

CHEEK BENDER

**Best Value
Best Price!**



**PART NO.
168002420**

The Original Cheek Bender

24 inch • 20 gauge.
Double Sided
2 Flange Settings with
adjustable tooling included

NEW

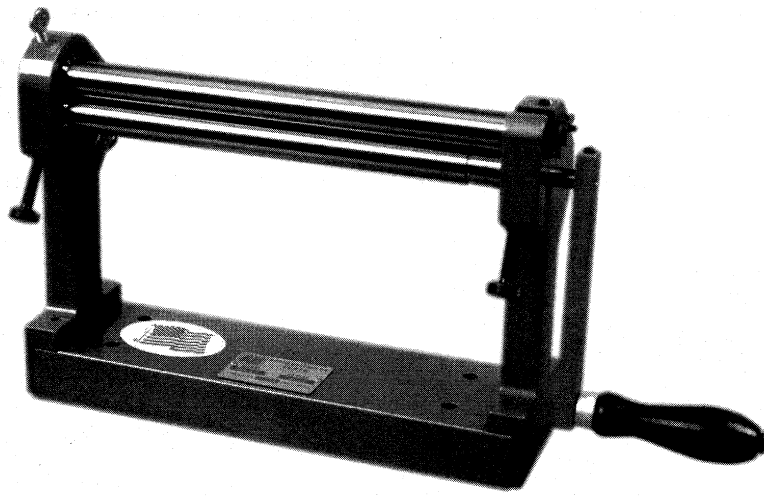

**SR-12
Precision Roller**

Your can make sheet metal do what you want it to with this quick forming machine. Perfect circles if you like. Or bend a sheet of metal at any point in a wide variety of shapes. Engaging and disengaging that metal is simple. Lower roller adjusts easily for material thickness. Also has wire grooves 1/8" and 1/16".

**The 1" DIA. Top Roller is Slotted.
Specifications**

Maximum forming width	12"
Material capacity	22 gauge
Roll diameter	1"
Minimum radius	1"
Maximum radius	No limit
Net weight	28 lbs.
Part number	167070121

Features:

- Portable: 6" x 8" x 17" Guaranteed 1 year.
- Thumbscrew adjustments
- Gear covers
- Side supports
- Bronze roller bushings
- Mounting base
- Work resistant finish
- Work release cam
- Steel Rollers.

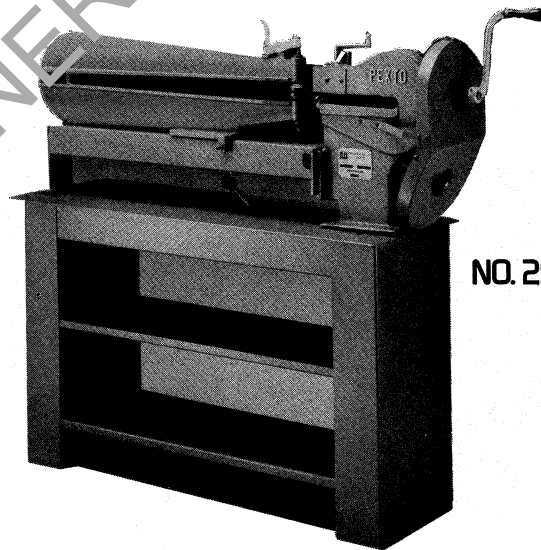

NO. 299

Ring & Circle Shears No. 299

The No. 299 shear has the capacity to cut circles in 3/4" to 42 1/2" square 20 gauge blanks. May be ordered with an optional floor mount stand.

Specifications

	No. 299	
	IN.	MM
Capacity, Mild Steel	20 Ga.	0.91
Depth, Cutting Head	10	254
Depth, Clamping Head	30 1/2	775
Blanks, Square	3/4 to 42 1/2	83 to 1,080
Height	23 1/2	597
Length	82	2,083
Width	21	533

NO. 63, NO. 055

A versatile, adjustable machine that performs many essential sheet metal operations using one motion to clamp and fold. No. 63 accommodates up to 30 inch lengths of a maximum 22 gauge, the No. 055 will fold maximum 36 inch lengths of up to 20 gauge mild steel. Quick set back gauge included. Steel floor stand is available as separate accessory.

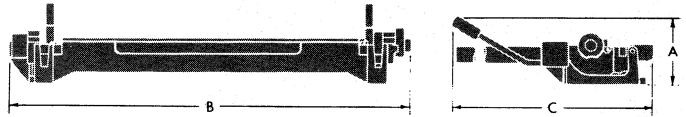
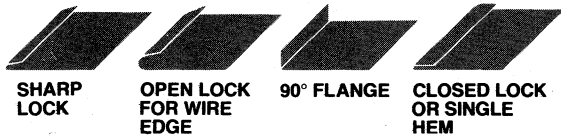

Dimensions

Reference	No. 63		No. 055	
	IN.	CM	IN.	CM
A	7	18	11	28
B	42	107	50	127
C	26	66	30	76

Specifications

Characteristics	No. 63	No. 055
Max. folding length (in.)	30	36
Capacity, mild steel (ga.)	22	20
Gauging range (in.)	1/8-1	1/8-1 1/4
Max. round fold dia. (for wire) (in.)	1/4	3/8

Ordering Guide

Description	Catalog No.	Weight (Lbs.)
No. 63 Bar Folder	154070063	243
Floor Mount Stand	239006006	100
No. 055 Bar Folder	154070055	420
Floor Mount Stand	239006007	150

FLOOR MOUNT STAND

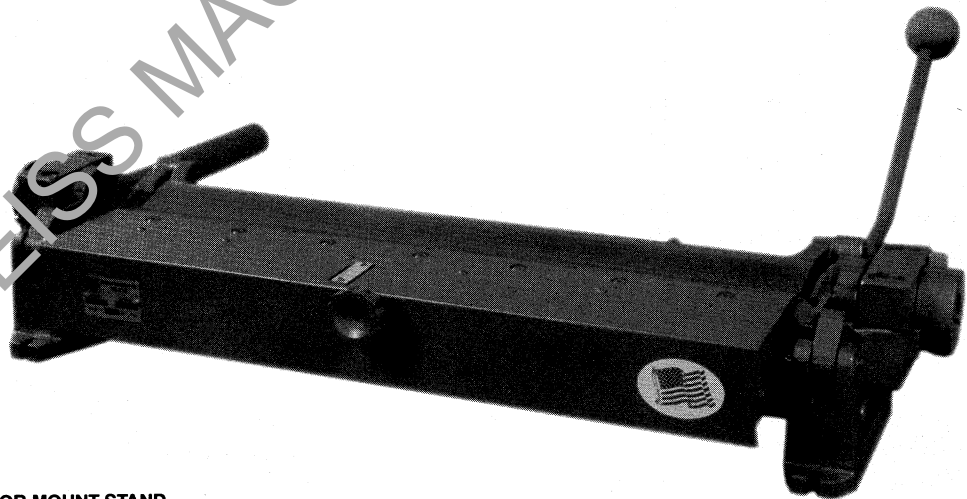
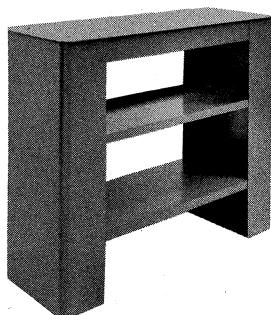

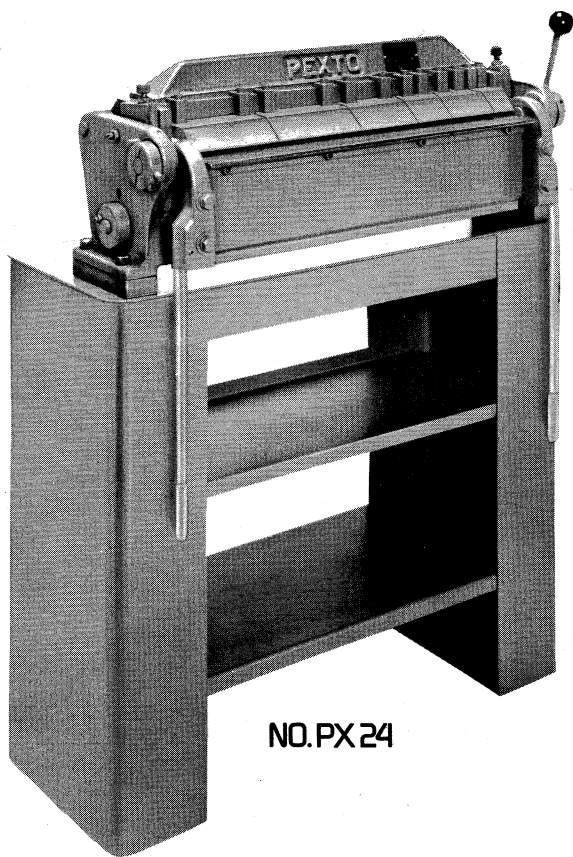

NO. PX 24

Light duty bending brakes are for light forming requirements (up to 16 gauge mild steel). When used within their rated capacity, they will form a minimum 1/2" flange over their entire length.

- **Maximum Rated Capacity:** 16 gauge mild steel (PX24)

The PX 24 Box and Pan Brakes with adjustable back gauge are ideal for small, precise box and pan work (up to 3" deep). Each will accommodate sheet metal up to 16 gauge. The PX24 will bend as much as a 135° angle in up to a 24-inch length. Standard fingers provided include one each 3/4", 1", 1 3/4", 1 1/2", 3", 4 1/2" and 6" (on PX24). Fingers are heat-treated die steel, precision ground. Set of fingers can be arranged to form 3/4" to 24" in 1/4" increments. Back gauge adjustment is from 0-24". Adjustable friction brake lock stops upper bar dead-weight drop and permits precise positioning of upper bar to scribed line on workpiece before final clamping. Both pan brakes have optional special fingers to adapt them to inside mitered lip boxes, 9" long square tubes and radius bends up to 1". Both are bench models. The floor mount stand shown must be ordered as a separate item (as indicated in the Ordering Guide).

Minimum 1/4" (PX24) reverse bends are possible with each of these light duty brakes by removing both the apron angle iron work support and apron filler plate and reducing the capacity by four gauges.

Ordering Guide

Description	Catalog No.	Weight (Lbs.)
Brakes (Bench Model)		
No. PX24***	155070024	270
Floor Stand PX24	239006006	160
Extension Finger PX24		
Right	251700107	3
Left	251700108	3
Open End Finger PX24	251700109	3
Radius Fingers PX24		
Specify radii and width desired		
Radii Available: 1/16", 1/8", 3/16", 1/4", 5/16", 3/8", 7/16", 1/2", 3/4", 1"		
Widths Available: 3/4", 1", 1 1/4", 1 1/2", 3", 4 1/2", 6"		

***PX24 brake standard equipment includes one each 3/4", 1", 1 1/4", 1 1/2", 3", 4 1/2" and two 6" box fingers.

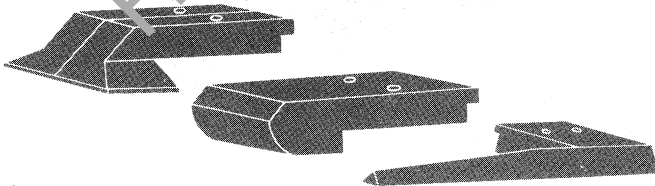

Extension Fingers PX24

For inside mitered lip boxes, minimum 2 1/2" square box.

Radius Fingers PX24

Available in widths of 3/4", 1", 1 1/4", 1 1/2", 3", 4 1/2" and 6" with radii of 1/16", 1/8", 3/16", 1/4", 5/16", 3/8", 7/16", 1/2", 3/4" and 1".

Open End Finger PX24

For square tubes up to 9" long.
Taper from 3/4" to 1 1/2".

Dimensions

Reference	Bench Models			
	No. PX24			
	IN.	CM	IN.	CM
A	34	86		
B	11	28		
C	28	71		
D	—	—		
Bench Mount Stand	34w x 30h x 14d			

Specifications

Characteristic	No. PX24			
	IN.	CM	IN.	CM
Capacity, Mild Steel	16 ga.	—		
Max. Bending Length	24	61		
Max. Jaw Opening	1	2.5		
Max. Bend Angle (past horizontal)	45°*	—		
Min. Flange Bend	1/2	1.3		
Min. Reverse Bend	1/4	0.6		

*Only 20° when box fingers are used.

CB3020 CLEAT BENDER

This manual operated machine forms uniform drive cleat edges and flanges on rectangular ductwork in seconds without set-up or adjustment. The upper handle forms the cleat or flange in a single pass for greater productivity. The lower handle opens for easy removal of the work material.

Stable cast iron beams and end housings form the basis for this precision engineered design. High quality hinges and ergonomic design guarantee long life and trouble free operation.



Specifications

Cleat Bender	Model CB3020
Maximum capacity, mild steel	20 ga.
Maximum bending	30 in.
Depth of drive cleat	1/2 in.
Dimensions, handles removed, LxWxH	39 x 9 x 9"
Shipping weight	145 lbs.

MAGNABEND NO. MBB 4181.



Electromagnetic Sheet Metal Bending Brake

Magnabend offers performance characteristics no conventional bending brake can match. The unique electromagnetic design of the keeper clamping system allows you to form many complex shapes not possible before. Plus, Magnabend can handle all regular shapes in light ferrous and non-ferrous sheet metal (up to 4' wide, 18 ga.) in a much simpler, less time consuming and efficient manner. The rugged, simple construction incorporating only one moving part assures low maintenance and versatility for all light duty forming requirements.

A wide variety of complex shapes can be formed with Magnabend. These include rolled edges up to 330°, partial length bends, closed shapes, unlimited depth for boxes and heavier material bends (up to 10 ga.) in shorter widths.



Also Available
in 2', 6', 8' and 10' models

Design Features Assure Quality

Simplicity is evident in Magnabend's electromagnetic design which eliminates a conventional upper beam and more complex finger arrangements. Keepers (clamping members) are simply positioned over the workpiece and are clamped in place electromagnetically when the bending beam is raised. Keepers self-adjust for material thickness as the apron moves.

- **Electromagnetic Design** Magnabend is designed to eliminate the hindrance of an upper beam with the introduction of an elongated electromagnet and keeper system.
- **Self Locating** A simple and effective method of locating the full length keeper is achieved by spring-loaded steel locator balls.
- **Triple Hinge System** Three hinges allow Magnabend to have a lighter bending beam without limiting durability and reliability.
- **Bend-Angle Gauge** Convenient bend-angle gauge features adjustable stop for precise, efficient repeat bends.
- **Back Gauge** Production efficiency in repeat bends is provided by adjustable back gauge.
- **Safety Features** The safety button engages a light magnetic force on the keeper. As well as a safety device, this force is a convenient way to stabilize the workpiece for precise measurement before you activate full clamping power.

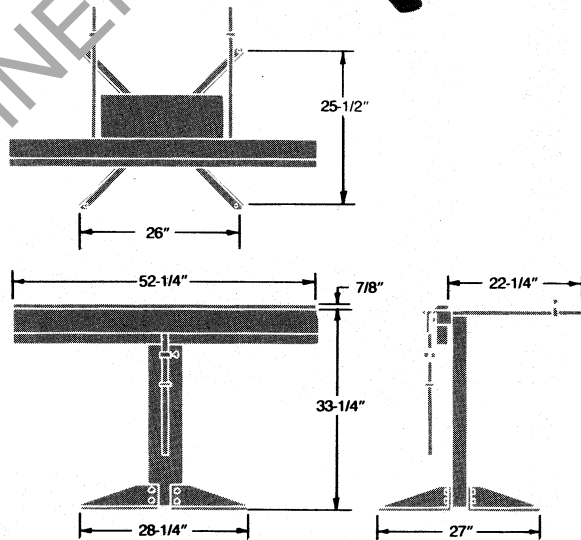

Specifications/Ordering Guide

Model MBB 4181

Input voltage: 115V, single phase,
60 hertz.

Input current: 12 amps.

Duty cycle: 20%

Maximum Bend Length: 49.38" — or 51" with manual location of keeper.

Full Length Bend Capacity: With 1.50" lip (extension piece fitted to bending beam) 18 ga. in mild steel or non-ferrous material. (Typical Bend Radius — .16")

Minimum Reverse Bend: 1.50" with work support; .75" without work support.

Keepers (Clamping Members): Both models furnished with 11 keepers — 3/4", 1", 1 3/8", 1 7/8", 2 3/4", 3 3/4", 4 3/4", 6", 12", 21 5/8", and full length 51 1/4".

Net Weight: 275 lbs. (Shipping weight 300 lbs.)

Connecticut

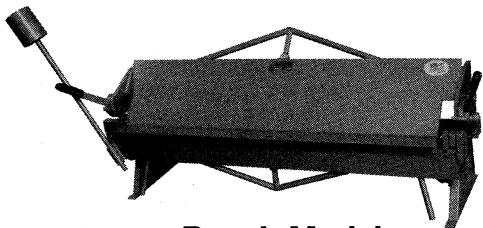

Bench Model

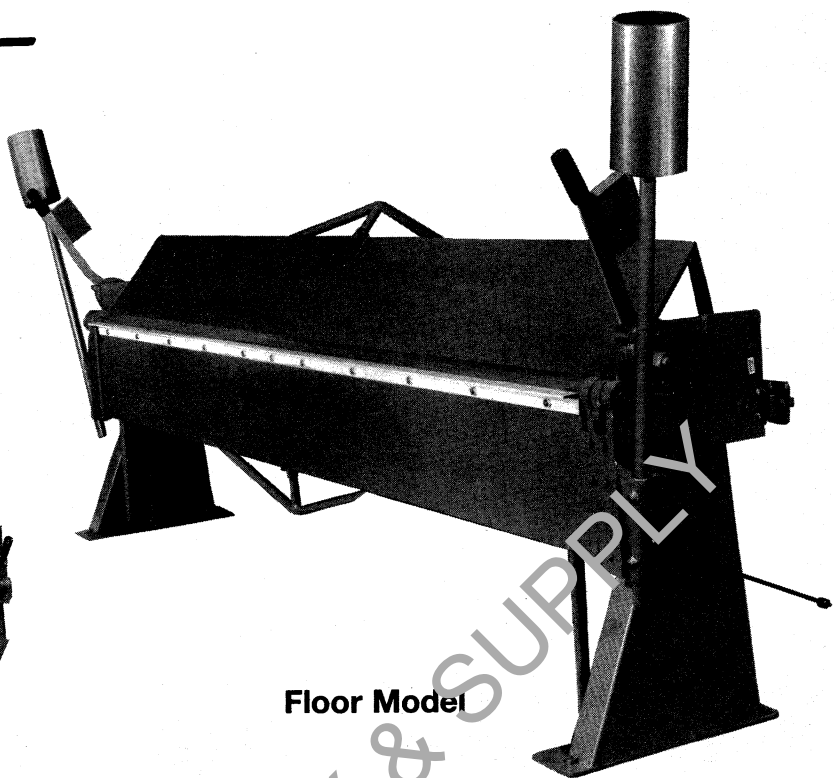

Floor Model

Specifications

	Model 816	Model 1016	Model 1018
Length of bed	97"	121"	121"
Capacity on mild steel, 1" flange,			
With bending bar and angle in place	16 ga.	16 ga.	18 ga.
With bending angle removed	20 ga.	20 ga.	22 ga.
With bending bar and angle removed	23 ga.	23 ga.	25 ga.
Minimum reverse bend (bar and angle removed)	1/4"	1/4"	1/4"
Maximum lift of beam	1 5/8"	2 1/4"	2 1/4"
Front to rear adjustment of beam	1 1/8"	1 3/8"	1 1/8"
Shipping weight	1640 lbs.	2660 lbs.	2200 lbs.

Specifications

	Model U414	Model U416
Length of bed	48"	48 1/4"
Capacity on mild steel, 1" flange,		
With bending bar and angle in place	14 ga.	16 ga.
With bending angle removed	18 ga.	20 ga.
With bending bar and angle removed	21 ga.	23 ga.
Minimum reverse bend (bar and angle removed)	1/4"	1/4"
Maximum lift of beam	1 5/8"	1 1/4"
Finger widths	3", 4", 5"	2", 3", 4"
Maximum depth of box	6"	4"
Front to rear adjustment of beam	1 1/8"	5/8"
Shipping weight (without bench)	1400 lbs.	495 lbs.
Bench (same used for light duty models)	—	Optional
Bench size	—	56" long, 18" wide, 26" high
Bench shipping weight (knocked down in carton)	—	100 lbs.

Specifications

	Model 422	Model U218	Model U422
Length of bend	48 1/4"	24 1/4"	48 1/4"
Capacity on mild steel,			
3/8" flange, full length	22 ga.	18 ga.	22 ga.
Maximum lift of beam	7/8"	7/8"	7/8"
Shipping weight	210 lbs.	155 lbs.	280 lbs.
Minimum reverse bend	5/16"	5/16"	5/16"
Finger widths	—	2", 3", 4"	2", 3", 4"
Maximum depth of box	—	3"	3"

All steel, welded construction. Bronze bushings or pins at points of wear. Plastic handle grips. Adjustment of beam from 0 to 1/8" back from edge of bed.

Combination Bending Brakes

- Up to 12 Gauge Maximum Capacity
- Up to 121" Maximum Work Length
- Lower Beam Clamping
- Bending Flexibility

The combination bending brakes are the most versatile brakes available from Roper Whitney. In addition to straight bending, box and pan work, inside bending, radius bending and other intricate forming operations are possible with the use of special fingers. Eight models are available in work lengths of 4', 6', 8' & 10' with maximum capacities of 12 gauge. They all feature Roper Whitney's unique lower beam clamping for safe, efficient operation.

When both the apron angle iron work support and the apron filler plate are removed, minimum 1/4" reverse bends may be made on all models except the 812 and 1012 (which permit 3/8").

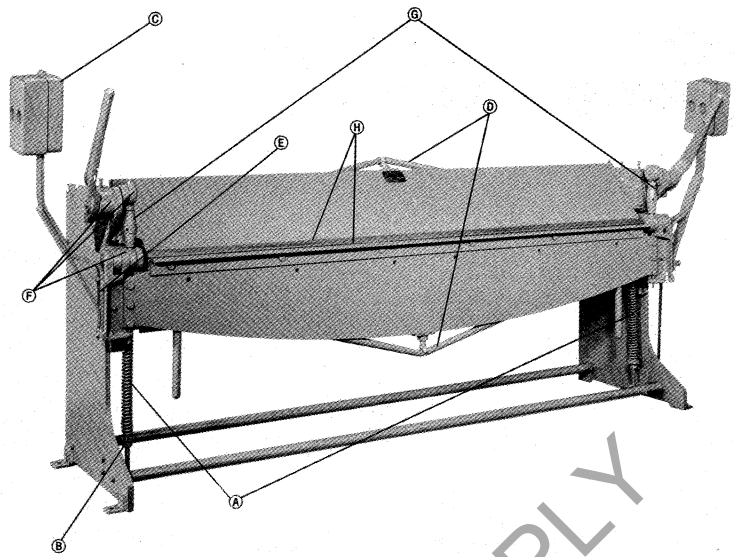

- (A) Heavy-duty lower beam spring
- (B) Spring adjustment nut
- (C) Adjustable counterweight
- (D) Heavy-duty truss rods
- (E) Adjustable apron angle gauge
- (F) High quality roller bearings
- (G) Clamping pressure adjustments
- (H) Removable upper & lower jaws

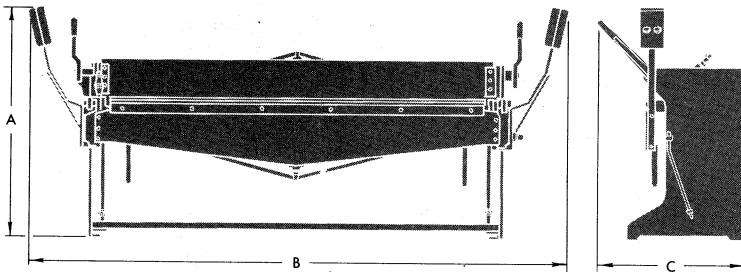

Dimensions

Reference	No. 412		No. 612		No. 812				No. 1012			
	IN.	CM	IN.	CM	IN.	CM	IN.	CM	IN.	CM	IN.	CM
A	60	152	60	152	67	170			67	170		
B	85	216	109	277	143	363			167	424		
C	43	109	43	109	46	117			46	117		

Specifications

Characteristic	No. 412		No. 612		No. 812				No. 1012			
	IN.	CM	IN.	CM	IN.	CM	IN.	CM	IN.	CM	IN.	CM
Capacity*, Mild Steel	12 ga.	—	12 ga.	—	12 ga.	—			12 ga.	—		
Maximum Bending Length	45	124	73	185	97	246			121	307		
Maximum Jaw Opening**	1 1/4	4.4	1 3/4	4.4	1 3/4	4.4			1 3/4	4.4		
Minimum Reverse Bend	1/4	.63	1/4	.63	3/8	.95			3/8	.95		
Minimum Flange Bend	1	2.5	1	2.5	1	2.5			1	2.5		
Maximum Bend Angle*** (past horizontal)	45°	—	45°	—	45°	—			45°	—		

*Brake capacity is reduced to 12 gauge when box fingers are used.

**May be increased to 4" to accept box fingers.

***Only 20° when box fingers are used.

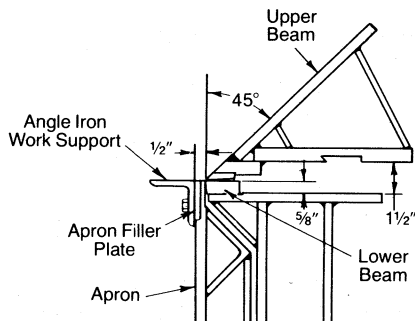

Ordering Guide

Description	Catalog No.	Weight (Lbs.)
No. 412 Brake	156000412	1620
No. 612 Brake	156000612	2280
No. 812 Brake	156000812	3580
No. 1012 Brake	156001012	5040

AUXILIARY ATTACHMENTS

Box Fingers

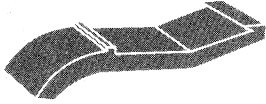

- Available in widths of 1", 1½", 2", 2½", 3", 3½", 4", 4½", 5", 5½", 6" & 8". Depths of 6" & 8".

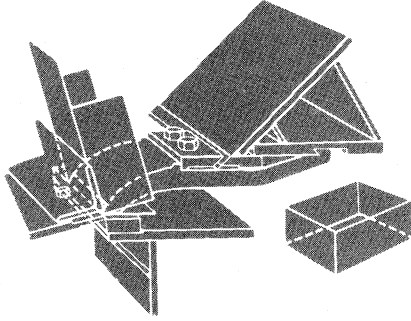

Radius Former Bars*

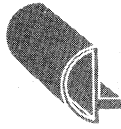

- Available in radii of ⅛", ⅜", ¼", ⅝", ⅜", ½", ⅝", ¾", 1", 1¼", 1½", 1¾", 2", 2¼" & 2½". Lengths of 4', 6', 8' & 10'.

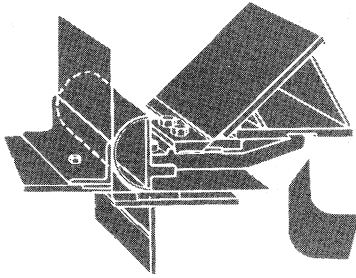

*Requires use of holder fingers: 3 for 4' brakes; 4 for 6' brakes; 5 for 8' brakes; 6 for 10' brakes.

Holder Fingers (for radius former bars)

Tinner's Moulds



- A complete set of five standard sizes (⅝", 1", 1⅝", 2¼" & 3") is available for each brake.

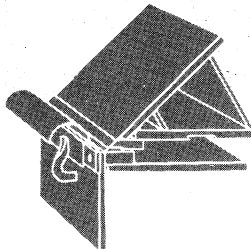

Ordering Guide

Box Fingers	Catalog No.		Weight (Lbs.)	
	6" Depth	8" Depth	6" Depth	8" Depth
1"	251566010	251568010	4	4.5
1½"	251566015	251568015	6	6.8
2"	251566020	251568020	8	9.0
2½"	251566025	251568025	10	11.3
3"	251566030	251568030	12	13.5
3½"	251566035	251568035	14	15.8
4"	251566040	251568040	16	18.0
4½"	251566045	251568045	18	20.3
5"	251566050	251568050	20	22.5
5½"	251566055	251568055	22	24.8
6"	251566060	251568060	24	27.0
8"	251566080	251568080	32	36.0

Ordering Guide

Radius Former Bars*	Catalog No.				Weight (Lbs.)			
	Brake				Brake			
	4'	6'	8'	10'	4'	6'	8'	10'
⅛"	352564012	352566012	352568012	352560012	33	47	64	79
⅜"	352564019	352566019	352568019	352560019	33	47	64	79
¼"	352564025	352566025	352568025	352560025	33	47	64	79
⅝"	352564031	352566031	352568031	352560031	33	47	64	79
⅜"	352564038	352566038	352568038	352560038	33	47	64	79
½"	352564050	352566050	352568050	352560050	15	22	29	36
⅝"	352564062	352566062	352568062	352560062	13	19	25	30
¾"	352564075	352566075	352568075	352560075	15	22	29	36
1"	352564100	352566100	352568100	352560100	23	34	45	56
1¼"	352564125	352566125	352568125	352560125	29	42	56	67
1½"	352564150	352566150	352568150	352560150	34	50	66	82
1¾"	352564175	352566175	352568175	352560175	39	58	77	96
2"	352564200	352566200	352568200	352560200	45	66	88	109
2¼"	352564225	352566225	352568225	352560225	50	75	98	122
2½"	352564250	352566250	352568250	352560250	55	82	109	136

*Shorter radius bars may be installed on larger brakes if desired.

Ordering Guide

Holder Fingers (for radius former bars)	Catalog No.	Weight (Lbs.)
3 pc. set (for 4' Brake)	251560001	28
4 pc. set (for 6' Brake)	251560002	37
5 pc. set (for 8' Brake)	251560003	46
6 pc. set (for 10' Brake)	251560004	56

Ordering Guide

Tinner's Moulds	Catalog No.	Weight (Lbs.)
Set for 4' Brake	253560004	25
Set for 6' Brake	253560006	38
Set for 8' Brake	253560008	52
Set for 10' Brake	253560010	65

NO. 137, NO. 152, NO. G52

Roper Whitney Pexto foot squaring shears are the industry's most accurate. They are easy to operate and offer precise shearing, long life and dependability. Shatter-proof transparent finger guards, treadle stops and well guards are among their safety features. All are provided with precise gauging and holddowns for cutting accuracy.

- Maximum Rated Capacity: 16 gauge mild steel
- Built to machine tool standards
- Triple-action shearing

No. 137 and No. 152 shears offer triple-action shearing which includes relief on both edges of both the fixed and moving blades. It eliminates blade-to-blade friction, provides "bite" to eliminate sheet movement under shearing stress and produces double penetration in the cutting action. All contribute to easier operation. The No. 137 will accommodate a 36" sheet, the No. 152 will handle a 52" sheet.

The No. G52 shear incorporates a gap-in-housing feature which permits slitting a sheet of any length (by successive cuts) up to 18 inches wide. Its gauging package is similar to the No. 137 and No. 152 shears, but also has an adjustable side slitting gauge. It may also be used for standard shearing of sheets up to 52 inches long. It includes a lever actuated holddown, finger guard and treadle stops.

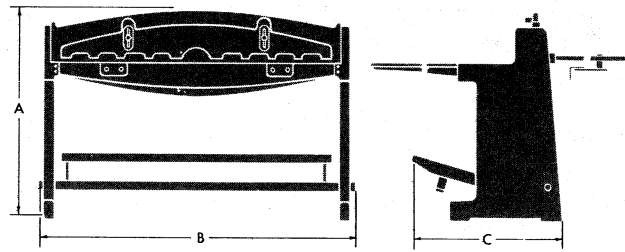
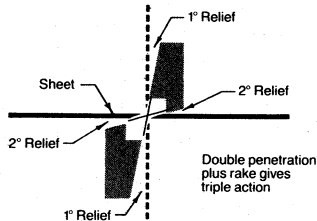

Dimensions

Reference	No. 137		No. 152		No. G52	
	IN.	CM	IN.	CM	IN.	CM
A	40	102	42	107	60	152
B	45	114	60	152	91	231
C	27	69	34	86	55	140

Specifications

Characteristic	No. 137	No. 152	No. G52
Maximum shearing length	37"	52"	52"*
Maximum back gauge range	25"	25"	25"
Maximum front gauge range	30"	30"	30"
Maximum slitting gauge range	—	—	18"
Floor space, gauges in position	45" x 76"	60" x 76"	91" x 78"
Max. rated capacity, mild steel	16 ga.	16 ga.	16 ga.

*For standard shearing. Length unlimited when using as a slitter (up to 18" widths).

Ordering Guide

Description	Catalog No.	Weight (Lbs.)
No. 137 Shear	162001371	700
Hi-Speed Blade Upper	350700190	—
Lower	350700191	—
No. 152 Shear	162001521	1000
Hi-Speed Blade	350700193	—
No. G52 Shear	162007521	1850
Hi-Speed Blade*	350700195	—

*Upper & lower blades are identical.

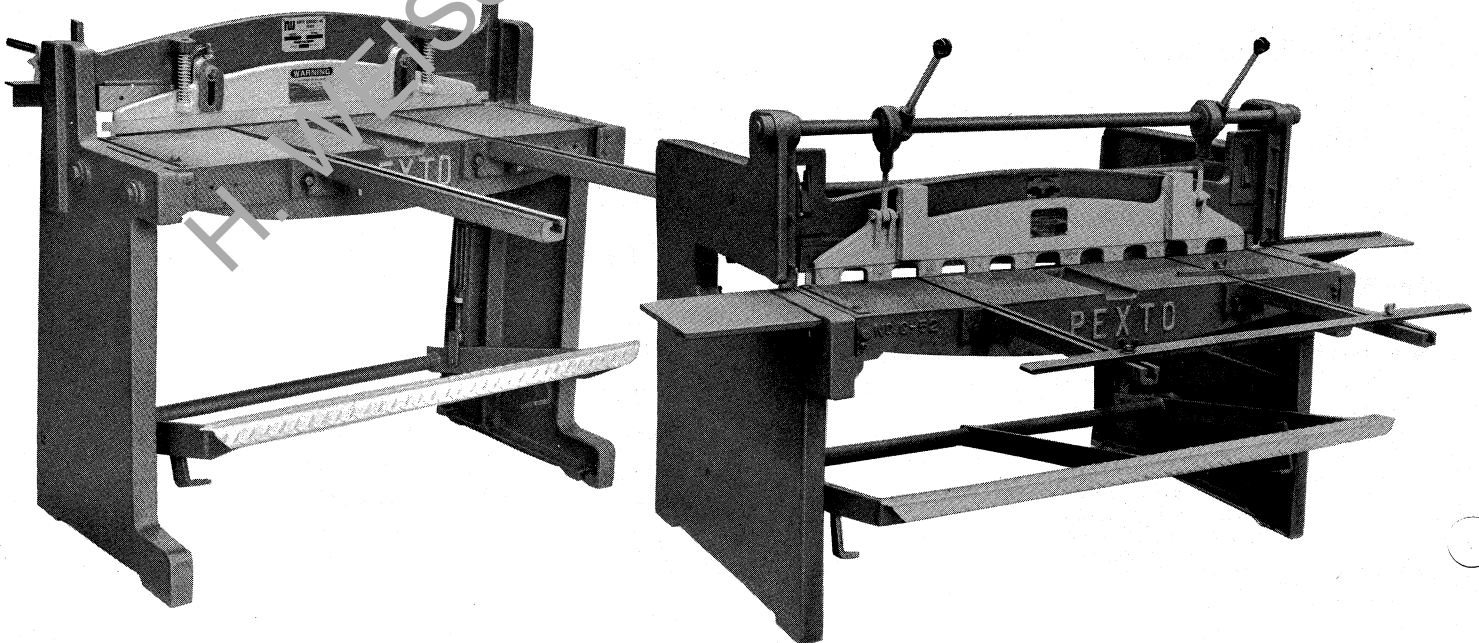

NO. PH52, PH452

Roper Whitney power squaring shears provide many choices of features designed for shearing efficiency and accuracy to equal the demand of present day productivity. Both the hydraulically operated (PH37 and PH52) and the mechanically operated models have built-in ruggedness that will make them last for years of normal use. Within the many models is the capability to shear up to 12 gauge mild steel and up to 6 foot sheet lengths. Some models are designed to provide power shearing in a compact unit for use where space is a consideration. All include precise gauging and appropriate safety guarding.

- Max. Rated Capacity—16 gauge (mild steel)
- 52" Shear Lengths

Compact, fully-integrated, hydraulically powered units. Ideal for many light gauge shearing applications. Equipped with big shear operating controls. Fast, smooth, oil-cushioned action. Both moving and fixed blades are shearing blades of Hi-Speed steel. One piece cast shear bed is recessed for easy sheet handling. Standard equipment includes back, front and side gauges, bevel gauge, front arms and transparent finger guard. Bed is machined for optional side extension squaring gauge.

Other features include:

- Fully enclosed control panel, with magnetic starter, selector switch and relays.
- Single or continuous stroke operation.
- Heavy duty foot switch. If released anywhere in the stroke, crosshead returns to "up" position.
- Pressure relief valve to prevent overloading.
- Electric solenoid hydraulic valving for instantaneous response.
- Dial stroke control—accessible adjustment with stroke length indicator.
- Hydraulic power uniformly applied through double-acting cylinders.

NOTE - PH452 SHEAR DOES NOT HAVE CONTINUOUS STROKE CYCLE OR THE FRONT ARM ASSEMBLY

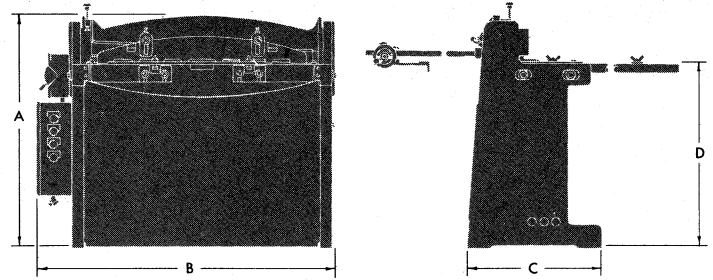

Dimensions

Reference	No. PH52		PH452	
	IN.	CM	IN.	CM
A	42	107	42	107
B	66	168	66	168
C	26	66	26	66
D	32	81	32	81

Specifications

Characteristic	No. PH52	PH452
Maximum shearing length	52"	52"
Maximum back gauge range	25"	25"
Maximum front gauge range	37"	—
Floor space, gauges in position	66" x 76"	66" x 76"
Maximum rated capacity, mild steel	16 ga.	16 ga.
Standard motor	2 hp	2 hp
	1800 rpm, 3-phase	1800 rpm, 3-phase

Ordering Guide

Description	Catalog No.	Weight (Lbs.)
Hi-Speed Blade*	350700193	—
No. PH52 Shear	191319521	1300
No. PH452 Shear	191314521	1300

*Upper & lower blades are identical.
Please specify electrical requirements.

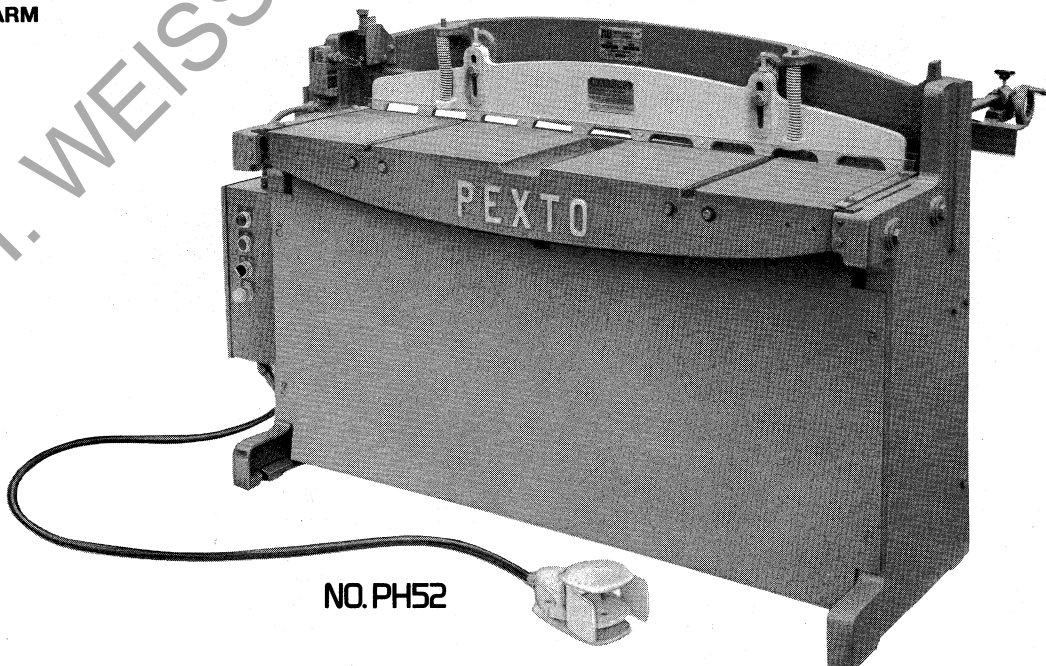

NO. PH52

10M14 MECHANICAL SHEARS

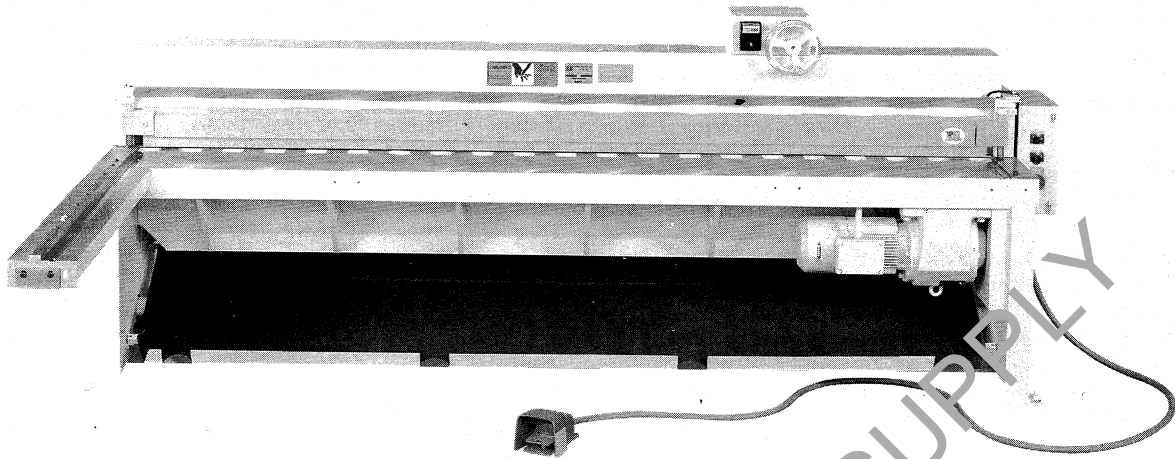

Specifications

Characteristic	6M14	10M14
Capacity	14 ga. mild steel	14 ga. mild steel
Working Length	78.5 inches	121.25 inches
Back Gauge Travel	24 inches	24 inches
Approximate Weight	4000 lbs.	5500 lbs
Power	5 hp	5 hp
Standard Voltage	230 vac 3 hp 60 hz	230 vac 3 hp 60 hz
Strokes Per Minute	32	35

10M10 MECHANICAL SHEARS



Specifications

Characteristic	10M10
Capacity	10 ga. mild steel 12 ga. stainless steel
Working Length	122 inches
Back Gauge Travel	30 inches
Approximate Weight	6300 lbs.
Power	7-1/2 hp
Standard Voltage	230 vac 3 hp 60 hz
Strokes Per Minute	43

HYDRAULIC SHEARS

10 GAUGE AND 1/4 INCH



MODEL 10H8

- Heavy-duty welded frame and removable front panels allow units to be moved by forklift plus lift rings on top of units for hoisting shears with slings.
- Standard electric motor and hydraulic pump system assures reliable performance and convenient maintenance.
- Hinged front and side panels open for easy access to motor/pump systems.
- Variable speed back gauge has an easy-to-reach push button control on the front side of the shear for more efficient operation.
- Adjustable rake eliminates curl and twist in cutting.
- 4' side-squaring arm with recessed scale and fixed stop. Optional swing stop available.
- Four-edge HCHC blades produce clean, true cuts.
- Optional overhead light beam for precise shearing on scribed line.
- Fully guarded foot switch on 10" cord for remote operation (can be unplugged).
- "Safety yellow" finger guard on front and see through guard on top for maximum operator safety.
- Electrical disconnect and controls meet ANSI standards.

10 GAUGE SPECIFICATIONS/14 GA. STAINLESS STEEL

Common to all models

Maximum cutting capacity (mild steel)-10 gauge
 Back gauge extension-36"
 Front to back dimension with gauging-96"
 Height-54"
 Table Height-32"
 Strokes per minute-20 (Maximum rake angle and full stroke)
 Working pressure-2,200 p.s.i.
 Voltage-Standard 230v, 3 phase, 60Hz (with 110V control circuit)-Optional 208 or 440V, 3 phase

MODEL	10H5	10H6	10H8	10H10	10H12
Cut Length	5'	6'	8'	10'	12'
Length (overall)	7'	8'	10'	12'	14'
Est. ship wt. (lbs.)	4,700	6,700	7,700	8,750	13,000
Horsepower	5	10	10	10	10

1/4" SPECIFICATIONS/8 GA. STAINLESS STEEL

Common to all models

Maximum cutting capacity (mild steel)-1/4 inch
 Back gauge extension-36"
 Front to back dimension with gauging-132"
 Height-63"
 Table Height-32"
 Strokes per minute-4'-20, 6'-18, 8'-17 and 10'-15
 Working pressure-2,250 p.s.i.
 Voltage-Standard 230v, 3 phase, 60Hz (with 110V control circuit)-Optional 208 or 440V, 3 phase

MODEL	25H4	25H6	25H8	25H10
Cut Length	4'	6'	8'	10'
Length (overall)	78"	102"	126"	150"
Est. ship wt. (lbs.)	7,500	8,400	9,500	11,000
Horsepower	15	15	15	15

NO. 58

- Maximum Rated Capacity:*
5 tons
- Foot operated
- 18 inch throat depth

These toggle action foot presses offer the distinct advantage of freeing both hands to position the stock, as well as providing close, nearly effortless control of the punching cycle. The throat depth allows you to punch 18 inches from the edge of the material.

*Refer to the tonnage chart on page 32 to determine if the rated capacity of this tool will accommodate the type and thickness of metal and the size and shape hole that you will be punching. Do not, under any condition, exceed the rated capacity of this tool.

Auxiliary Attachments

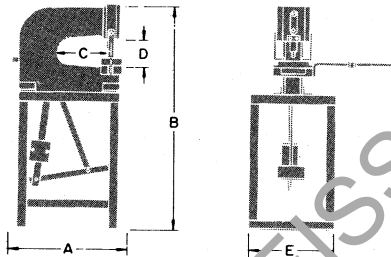
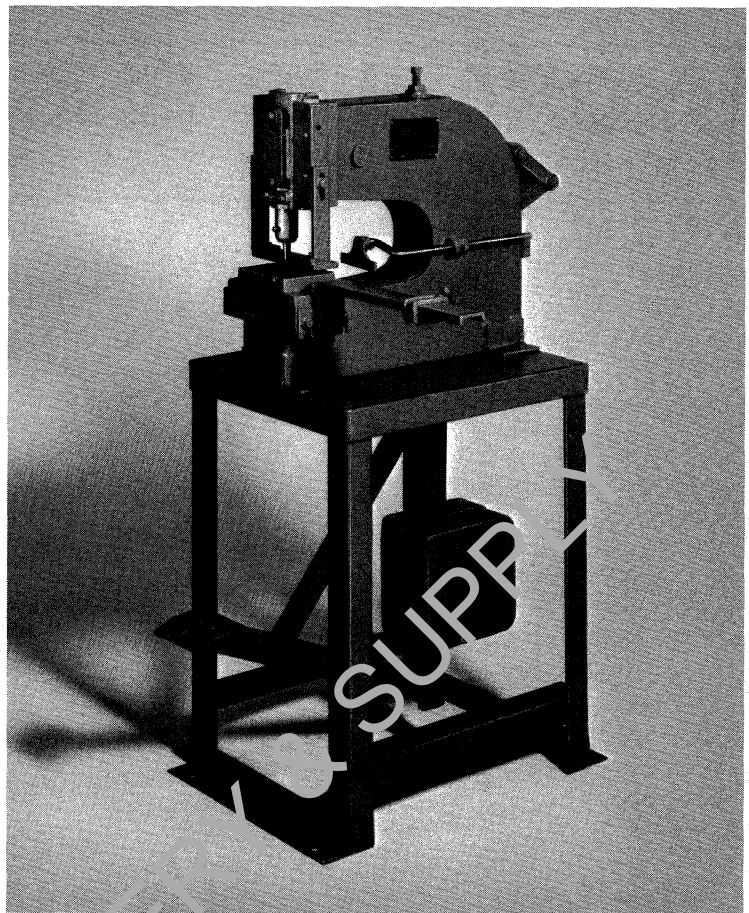
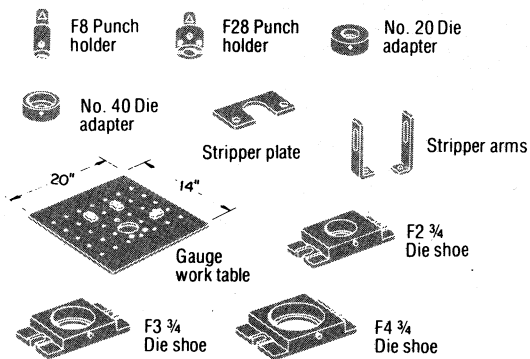

Dimensions

Reference	No. 58	
	IN.	MM
A	34	865.6
B	48	1219.2
C	18	457.2
D	5 3/4	146.05
E	18	457.2

	IN.	MM
Length of stroke	1	25.4
Adjustment of ram	3/4	19.05
Die space with stroke down, adjustment up	5	127.0
Diameter of punch shank hole in ram	1	25.4
Depth of punch shank hole in ram	1 1/4	31.75
Slug clearance	3 x 5	76.2 x 127.0
Bed plate holes (C to C)	6 3/4	171.45
Bed plate dimensions	4 1/2 x 8 1/4	114.3 x 209.55

Ordering Guide

Description	Catalog No.	Weight (Lbs.)
No. 58 Foot Press*	132050580	505
F8 punch holder	136122808	2
F28 punch holder	136132828	2
No. 20 die adapter	136313020	2
No. 40 die adapter	136323040	1
F2 3/4 die shoe	139404030	8
F3 3/4 die shoe	139415050	9
F4 3/4 die shoe	139426060	14
Stripper arms (2)	232930001	3
Stripper plate:		
A7 (1/2" max. punch)	332200500	2
B7 (1" max. punch)	332201000	2
C7 (2" max. punch)	332202000	3
D7 (3" max. punch)	332203000	3
E7 (4" max. punch)	332204000	3
Gauge work table	137000320	18

*Includes standard equipment: Side gauge, depth gauge, one F8 and F28 punch holder, one No. 20 and No. 40 die adapter, F2 3/4" die shoe, one set 1/2" round punch and die, one set stripper arms, A7 stripper plate.

Punches and Dies

Order additional punches and dies from Roper Whitney Punch & Die Price List.

Typical Size Ranges

	Type O	Type M	Type N	Type P	Type R	Type S	Type T	Type D
No. 29, 58 & 68	1/8-4	1/8 x 3/16 3 x 3 3/4	1/8 x 3/16- 2 x 3 1/4	1/8 x 3/16- 3 x 3 3/4	1/8- 2 5/8	5/32- 1 1/2	5/32- 1 1/4	5/32 x 1/8- 4 x 3 3/8

NO. 34

- Maximum Rated Capacity:*
8 tons
- Linear Actuation
- Standard and deep throat models

This lever press provides power press capacity with manual press economy for prototype and short run work. Their large throat openings accommodate a wide variety of part sizes and shapes.

*Refer to the tonnage chart on page 32 to determine if the rated capacity of this tool will accommodate the type and thickness of metal and the size and shape hole that you will be punching. Do not, under any condition, exceed the rated capacity of this tool.

Auxiliary Attachments

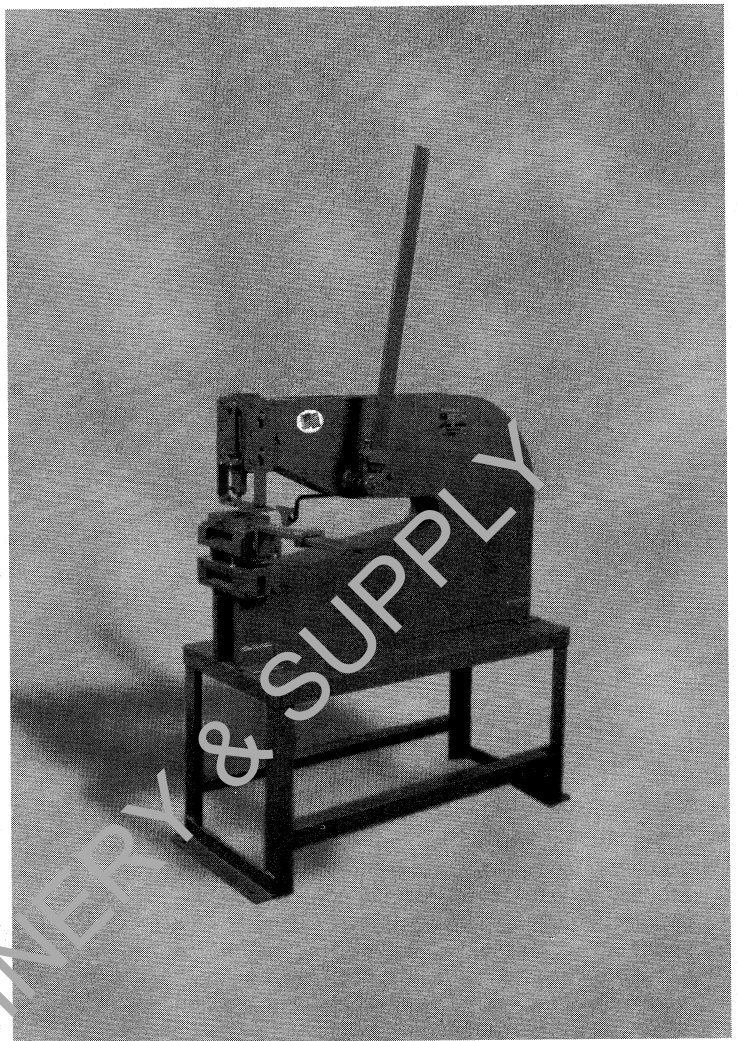
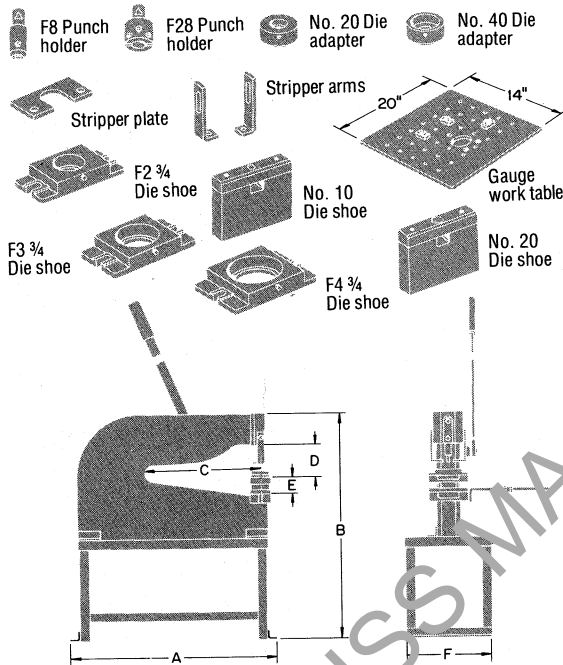

Ordering Guide

Description	Catalog No.	Weight (Lbs.)
No. 34 Lever Press*	132040340	770
F8 Punch holder	136122808	2
F28 Punch holder	136132828	2
No. 20 Die adapter	136313020	2
No. 40 Die adapter	136323040	1
No. 10 Die shoe	139541010	15
No. 20 Die shoe	139552020	16
F2 3/4 Die shoe	139404030	8
F3 3/4 Die shoe	139415050	9
F4 3/4 Die shoe	139426060	14
Stripper arms (2)	232930001	3
Stripper plate:		
A7 (1/2" max. punch)	332200500	2
B7 (1" max. punch)	332201000	2
C7 (2" max. punch)	332202000	3
D7 (3" max. punch)	332203000	3
E7 (4" max. punch)	332204000	3
Gauge work table	137000320	18

*Includes standard equipment: Side gauge, depth gauge, one F8 and F28 punch holder, one No. 20 and No. 40 die adapter, F2 3/4" die shoe, one 1/2" round punch and die, one set stripper arms, A7 stripper plate, and 48" bar handle.

Dimensions

Reference	No. 34	
	IN.	MM
A	44	1117.6
B	48	1219.2
C	24	609.6
D	6	152.4
E	4	101.6
F	18	457.2

	IN.	MM
Throat height at ram	10	254.0
Throat depth, No. 34	24	609.6
Length of stroke	1	25.4
Ram adjustment	3/4	19.05
Bed plate holes (C to C)	6 3/4	171.45
Dia. of punch shank hole in ram	1	25.4
Depth of punch shank hole in ram	1 1/4	31.75
Slug clearance	3 x 5	76.2 x 127.0

Punches and Dies

Order additional punches and dies from Roper Whitney Punch & Die Price List.

Typical Size Ranges

	Type O	Type M	Type N	Type P	Type R	Type S	Type T	Type D
No. 32, & 34	1/8-4	1/8 x 3/16-3 x 3/4	1/8 x 3/16-2 x 3/4	1/8 x 3/16-3 x 3/4	1/8-2 5/8	5/32-1 1/2	5/32-1 1/4	5/32 x 1/8-4 x 3/8

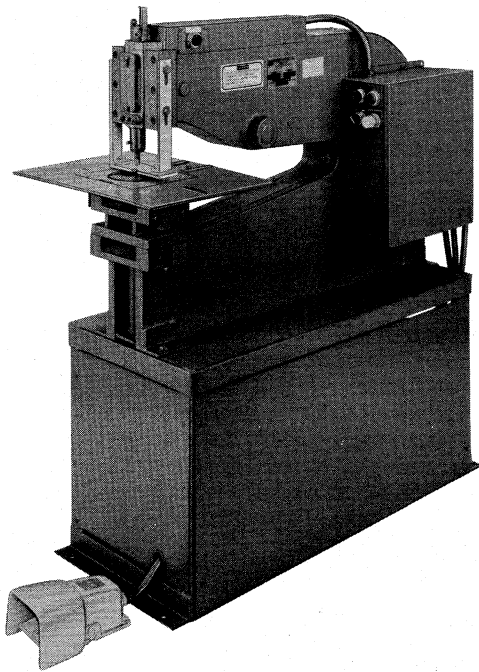

Auxiliary Attachments

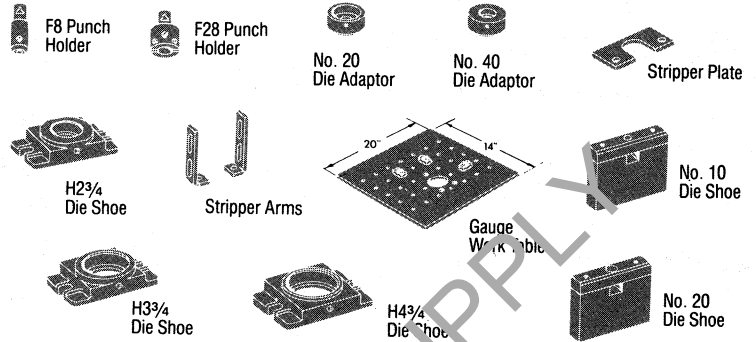

- Maximum rated capacity: * 8 tons
- Throat depths up to 24"

Designed for the small shop, this press economically upgrades production capability. For convenient set-up, operator efficiency and increased productivity the press has a control system that allows the operator to choose jog (for set-up) or run (for production) simply and conveniently. It also has adjustable stroke length and a full "override" capability.

Specifications

Characteristic	IN.	MM.
Throat height at ram	10	254.0
Throat depth	24	609.6
Length of stroke	1	25.4
Ram adjustment	3/4	19.05
Bed plate holes (C & C)	6 3/4	171.45
Dia. of punch shank hole in ram	1	25.4
Depth of punch shank hole in ram	1 1/4	31.75
Slug clearance	3 x 5	76.2 x 127.0

Ordering Guide

Description	Catalog No.	Weight (lbs.)
No. 134 Hydraulic Press*	133310134	900
F8 Punch holder	136122808	2
F28 Punch holder	136132828	2
No. 20 Die adaptor	136313020	2
No. 40 Die adaptor	136323040	1
No. 10 Die shoe	139541010	15
No. 20 Die shoe	139552020	16
H2 3/4 Die shoe	233450001	8
H3 3/4 Die shoe	233460001	9
H4 3/4 Die shoe	233470001	14
Stripper arms (2)	233940003	3
Stripper plate:		
A7 (1/2" max. punch)	332200500	2
B7 (1" max. punch)	332201000	2
C7 (2" max. punch)	332202000	3
D7 (3" max. punch)	332203000	3
E7 (4" max. punch)	332204000	3
Gauge work table	233940002	18

*Refer to the tonnage chart in Roper Whitney catalogs to determine if the rated capacity of this tool will accommodate the type and thickness of metal and the size and shape hole that you will be punching. Do not, under any condition, exceed the rated capacity of this tool.

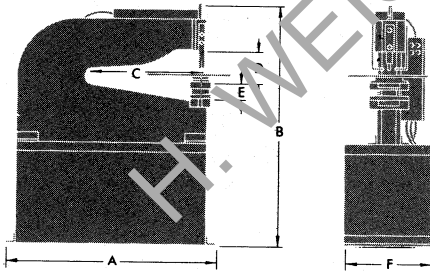

Dimensions

Reference	IN.	MM.
A	44	1117.6
B	51	1295.4
C	24	609.6
D	6	152.4
E	4	101.6
F	18	457.2

*Includes standard equipment: Side gauge, depth gauge, one F8 and F28 punch holder, one No. 20 and No. 40 die adaptor, H2 3/4" die shoe, one 1/2" round punch and die, one set stripper arms, A7 stripper plate. Gauge work table.

Typical Size Ranges

	Type O	Type M	Type N	Type P	Type R	Type S	Type T	Type D
No. 134	1/8-4	1/8 x 3/16-3 x 3/4	1/8 x 3/16-2 x 3/4	1/8 x 3/16-3 x 3/4	1/8-2 5/8	5/32-1 1/2	5/32-1 1/4	5/32 x 1/8-4 x 3/8

HOSE/CABLE ASSEMBLIES

Ordering Guide

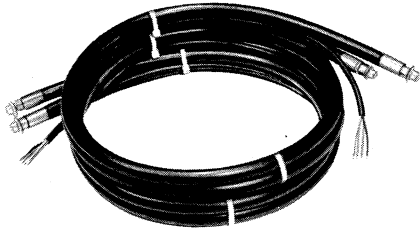

Description	Use With	Catalog Number		
		10 ft.	15 ft.	20 ft.
Two 3/8" i.d. hydraulic hoses w/fittings, one insulated electrical 4-conductor cable w/connectors, strapped	HP501, Power Units	181010501	181015501	181020501

Note: All hoses have a 1/4" male pipe fitting at both ends.

HP501

HP520

Standard Throat punches are designed to provide hole punching up to 4 3/8" from the edge of a variety of flat stock thicknesses. Because of their "standard" throat configuration, they provide a smaller overall package than the Deep Throat punches or Special Function punches with equivalent punching power.

HP520—The most versatile general purpose tool, with 20 ton capacity to punch round and irregular shapes, and set rivets. Combines power with portability, and may be bench mounted as well. May be used with beveled die to accommodate channel iron flanges. Used with power unit or hand pump. Includes punch coupler wrench and 1/2" dia. punch and die.

A = 13"
B = 5 1/2"
C = 4 1/2"
D = 2 1/4"
E = 5/8"
F = 7/8"
G = 2 1/4"
H = 3 1/6"
I = 3 1/4"
N = 3 5/16"

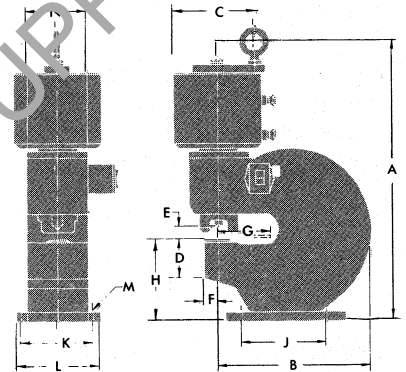

HP501 Model D

Max Cap. 4500 P.S.I.
115 Volt
1 1/2 HP 4 way solenoid control valve. External high pressure relief valve.
Oil-filled 2 gallon cast aluminum reservoir.
Casters on bottom for mobility.

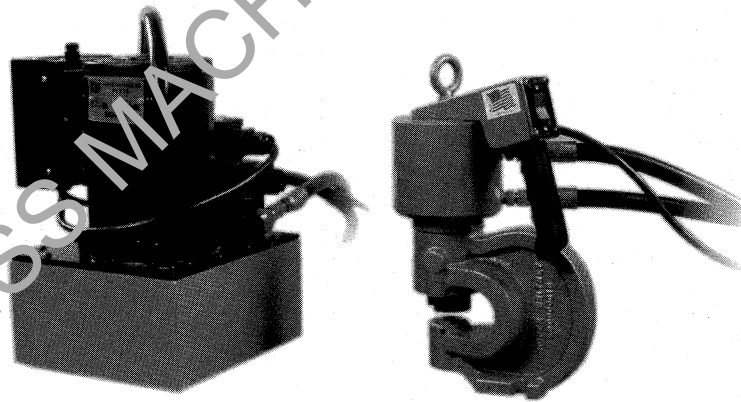

Ordering Guide

Model No.	Description	Capacity (Tons)	Typical Punching Capacity	Bore Dia. (In.)	Stroke (In.)	Weight (Lbs.)	Catalog No.	Recommended Power Unit
HP520	Portable; heavier & greater capacity than HP512A. Includes 1/2" dia. punch & die. Optional bench mount base.*	20	1/2" dia. thru 1/2" mild steel in 5 sec. w/HP501	3%	7/8	36	180000520	HP501 or HP507

TECHNICAL REFERENCE DATA

Selecting a Punch or Press

The following information, while not totally applicable to all fabricating machinery included in this catalog, is provided as a convenient general reference for metal punching operations up to and including large power presses. Specific questions not answered by this data may be directed to Roper Whitney without obligation.

Hole Size vs. Material Thickness

Punching holes in metal is the fast, economical way to get precise hole size, smoothness and minimum burr. Compressive strength of the punch steel determines that the thickness of the metal being punched must not exceed the diameter of the punch. This relationship varies with the type of material. For example: the minimum hole diameter will be $\frac{1}{4}$ " in $\frac{1}{4}$ " mild steel, $\frac{1}{4}$ " in $\frac{3}{16}$ " stainless steel, and $\frac{1}{4}$ " in $\frac{5}{16}$ " aluminum.

Maximum Rated Capacity

All punching tools have their maximum capacities for safe, dependable operation over a long life span. Tools listed in this catalog have a "rated capacity" based on their design strength. Before selecting a tool, use the following charts to determine the specific tonnage required to punch the size and shape holes through the type and gauge metal considered. These figures are for flat punch points. Shear on the punches (explained later) will reduce the tonnage required.

Determining Tonnages

For Round Holes

To determine tonnages for hot rolled mild steel (typically used in bar size angle iron, channels, tees and zeeks) with a 50,000 psi shear strength, read direct from chart #1.

Example: To punch a 4" diameter hole thru 20 gauge mild steel, the chart shows 11.3 tons are required.

For ASTM A-36 steel (typically used for structural size angle, flange, H and I beams, tees and zeeks) with a 60,000 psi shear strength, read direct from chart #2.

Example: To punch a $\frac{1}{4}$ " round hole in No. 10 gauge A-36 steel, the chart shows 3.2 tons pressure is needed.

For other metals select the proper multiplier from chart #3, and apply it to the tonnage figure for mild steel shown in chart #1.

Example: To punch a 4" diameter hole thru 20 gauge #202 stainless steel with a 1.8 multiplier, calculate as follows: 11.3 tons \times 1.8 = 20.3 tons required.

For Irregular Shape Holes

For punching irregular shaped holes (square, rectangular, obround, triangular, etc.) multiply the length of metal to be cut by the multiplier given for a 1" length in chart #4.

Example: The shear length (or total distance around a 1" \times 2" rectangular hole) is 6". To punch such a hole in 20 gauge mild steel multiply 6" \times 1.01 (from chart #4) = 6.06 tons. For stainless steel this would be 6 \times 1.50 = 9.0 tons.

Die Clearance

The relationship of the larger die hole size to the punch size is die clearance and is stated as a percentage of the thickness of the material being punched. The range of clearances varies from 10% for thin materials to 20% for thicker materials. For $\frac{3}{4}$ " material the total die clearance is .150". Clearance should always be specified when there is any reason for doubt.

Die Clearance has the following effects:

Too much clearance

1. Extra roll-in at top of the hole.
2. Too much burr at bottom of the hole.



Too little clearance

1. More punching pressure needed. Can reduce tool life.
2. High stripping force causes part distortion and extra punch wear.

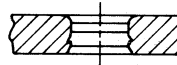

Correct clearance

1. Straighter hole thru material.
2. Minimum distortion at top of hole.
3. Minimum burr at bottom of hole.



Effects of die clearance are more noticeable in thicker materials (such as $\frac{1}{4}$ ") than in thinner materials (such as 16 gauge). Roper Whitney stocks #28 style dies with .006" clearance. For punching 24 gauge thru 14 gauge mild steel or most grades of aluminum, we recommend that you order the #28 style dies for generally satisfactory holes and fast delivery. For other gauges and material thicknesses and minimum burr, specify the type and thickness of material being punched and the exact clearance (see chart #5).

Shear

Shear may be added to most any punch ($\frac{1}{2}$ " or larger*) to reduce the shock load on machine components and the punch and die, and increase their life expectancy. Shear, in essence, proportions the force through part of the stroke length of the ram... much less material is being cut at any one time than would be with a punch without shear.

*There is no advantage of adding shear to smaller than $\frac{1}{2}$ ".

Two types of shear are added to most Roper Whitney punches:

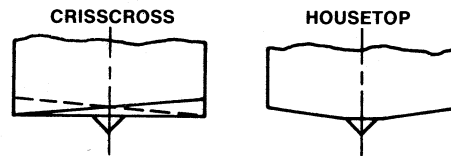

Round punches $\frac{5}{8}$ " diameter and larger, and square punches $1\frac{1}{16}$ " and larger have the "crisscross" shear. Rectangular and obround punches with 1" major dimension and larger have the "housetop" shear.

Shear is most effective when punching 14 gauge or lighter materials. It can reduce the punching force by as much as 50%.

Example: Chart #1 shows that 11.3 tons are needed to punch a 4" diameter hole thru 20 gauge mild steel. A punch with shear reduces the force to 5.7 tons.

Chart #1 Tons of Pressure Required To Punch Mild Steel

Round Hole Diameter		1/8"	3/16"	1/4"	5/16"	3/8"	7/16"	1/2"	9/16"	5/8"	1 1/16"	3/4"	13/16"	7/8"	15/16"	1"	1 1/2"	2"	2 1/2"	3"	3 1/2"	4"
Ga.	In.																					
20	.036	.4	.5	.7	.9	1.1	1.2	1.4	1.6	1.8	1.9	2.1	2.3	2.5	2.6	2.8	4.2	5.6	7.0	8.5	9.9	11.3
18	.048	.5	.7	.9	1.2	1.4	1.6	1.9	2.1	2.4	2.6	2.8	3.1	3.3	3.5	3.8	5.5	7.5	9.4	11.3	13.0	15.0
16	.062	.6	.9	1.2	1.5	1.8	2.1	2.3	2.6	2.9	3.2	3.5	3.8	4.1	4.4	4.7	7.0	9.5	11.7	14.0	16.5	18.8
14	.075	.7	1.1	1.5	1.8	2.2	2.6	2.9	3.3	3.7	4.0	4.4	4.8	5.1	5.5	5.9	8.8	11.7	14.7	17.6	20.5	23.5
12	.105	1.0	1.5	2.1	2.6	3.1	3.6	4.1	4.6	5.1	5.7	6.2	6.7	7.2	7.7	8.2	12.3	16.4	20.5	24.5	28.8	32.8
11	.120	1.2	1.8	2.4	2.9	3.5	4.1	4.7	5.1	5.9	6.2	7.1	7.6	8.3	8.8	9.4	14.0	18.8	23.5	28.2	32.7	37.6
10	.135	1.3	2.0	2.6	3.3	4.0	4.6	5.3	5.9	6.6	7.3	7.9	8.6	9.2	9.9	10.6	15.9	21.0	26.5	31.7	37.0	42.2
3/16"	.188	—	2.8	3.7	4.6	5.5	6.4	7.4	8.3	9.2	10.1	11.0	12.0	12.9	13.8	14.8	22.0	29.5	36.8	44.2	51.5	60.0
1/4"	.250	—	—	4.9	6.1	7.4	8.6	9.8	11.1	12.3	13.5	14.7	16.0	17.2	18.4	19.7	34.4	39.3	49.0	60.0	68.7	78.5
5/16"	.312	—	—	—	7.8	9.2	10.7	12.3	13.9	15.4	17.0	18.5	20.0	21.5	23.0	24.6	43.0	49.0	61.5	73.5	86.0	98.0
3/8"	.375	—	—	—	—	11.1	12.8	14.8	16.5	18.5	20.2	22.1	23.8	25.8	27.5	29.5	51.5	59.0	73.6	88.4	103.0	118.0
1/2"	.500	—	—	—	—	—	—	19.7	22.0	24.6	26.9	29.5	31.8	34.4	36.8	39.4	68.8	73.5	98.2	118.0	137.0	157.0

Chart #2 Tons of Pressure Required To Punch ASTM-A36 Structural Steel

Round Hole Diameter		1/8"	3/16"	1/4"	5/16"	3/8"	7/16"	1/2"	9/16"	5/8"	1 1/16"	3/4"	13/16"	7/8"	15/16"	1"	1 1/16"	1 1/8"	1 1/4"
Ga.	In.																		
12	0.105	1.2	1.9	2.5	3.1	3.7	4.3	4.9	5.6	6.2	6.8	7.4	8.0	8.7	9.3	9.9	10.5	11.1	11.7
1/8"	0.120	1.4	2.1	2.8	3.5	4.2	4.9	5.7	6.4	7.1	7.8	8.5	9.2	9.9	10.6	11.3	12.0	12.7	13.4
10	0.135	—	2.4	3.2	4.0	4.8	5.6	6.4	7.2	7.9	8.7	9.5	10.3	11.1	12.0	12.7	13.5	14.3	15.1
3/16"	0.187	—	3.3	4.4	5.5	6.6	7.7	8.8	9.9	11.0	12.1	13.2	14.3	15.4	16.5	17.6	18.7	19.8	20.9
1/4"	0.250	—	4.4	5.9	7.4	8.6	10.3	11.8	13.2	14.7	16.2	17.7	19.1	20.6	22.1	23.6	25.0	26.5	28.0
5/16"	0.312	—	—	7.4	9.2	11.0	12.9	14.7	16.5	18.4	20.2	22.0	24.0	25.7	27.6	29.4	31.3	33.0	34.9
3/8"	0.375	—	—	8.8	11.0	13.3	15.5	17.7	19.9	22.1	24.3	26.5	28.7	31.0	33.1	35.3	37.6	39.7	42.0
1/2"	0.500	—	—	—	—	—	—	23.6	26.5	29.4	32.4	35.3	38.3	41.2	44.2	47.1	50.0	52.9	55.9
3/8"	0.625	—	—	—	—	—	—	—	37.0	40.5	44.2	48.0	51.5	55.2	58.9	62.7	66.3	70.0	
3/4"	0.750	—	—	—	—	—	—	—	—	—	53.0	57.5	61.8	66.3	70.8	75.0	79.4	83.9	

Chart #3 Shear Strength

Material Description	Hardness	Ultimate		Multiplier For Chart No. 1	Material Description	Hardness	Ultimate		Multiplier For Chart No. 1
		Tensile (Tons)	Shear (Tons)				Tensile (Tons)	Shear (Tons)	
Steels					Aluminum Base*				
Low Carbon, H. R. Sheet	Rb 70	30	25	1.0	Alloy-Temper				
Low Carbon, C. R. Sheet					1100-0	BHN 23	6.5	4.5	.2
Structural Steel, ASTM A-36	Rb 70				-H14	BHN 32	9	5.5	.22
Low Carbon, C. R. Sheet					2024-0	BHN 47	13.5	9	.36
Soft	Rb 45-60	26.5	21	.84	-T3	BHN 120	35	20.5	.82
1/4 Hard	Rb 60-75	30	22.5	.9	3003-0	BHN 28	8	5.5	.22
1/2 Hard	Rb 70-85	36	25	1.0	-H14	BHN 40	11	7	.28
Hard	Rb 80-95	46	30.5	1.2	-H16	BHN 47	13	7.5	.3
.40- .50% Carbon Steel	BHN 200	50	40	1.6	3105-H25	BHN 47	13	8	.32
H. R. Sheet					5005-H34	BHN 41	11.5	7	.28
SAE 1074 C. R. Annealed	Rb 90	42.5	37.5	1.5	5052-0	BHN 47	14	9	.36
Spring Steel					5052-H32	BHN 60	16.5	10	.4
SAE 1095 C. R. Annealed	Rb 95	50	40	1.6	6061-0	BHN 30	9	6	.24
Spring Steel					-T6	BHN 95	22.5	15	.6
SAE 1074 or 1095	Rc 45-50	130	100	4.0	7075-0	BHN 60	16.5	11	.44
Spring Steel					-T6	BHN 150	41.5	24	.96
Hardened to Spring Temper					Copper Base				
Abrasion-Resisting	BHN 200/245	60	50	2.0	Alloy-Temper				
H. R. Steel Sheet					110-Electrolytic Tough Pitch Copper				
Cor-Ten Steel	BHN 140	35	27.5	1.1	- .050 mm G. S.	Rf 40	16	11	.44
Tri-Ten Steel	BHN 120	30	25	1.0	- 1/2 Hard	Rb 40	21	13	.52
T-1 Steel Types A & B	BHN 260	65	52.5	2.1	- Hard	Rb 50	25	14	.56
100,000 P. S. I. Y. S.					220 Comm. Bronze, 90%				
					- 1/2 Hard	Rb 58	26	17.5	.7
					230 Red Brass, 85%-1/4 Hard	Rb 55	25	17.5	.7
					260 Cartridge Brass, 70%				
					- .035 mm G. S.	Rf 68	24.5	17	.68
					- 1/2 Hard	Rb 70	31	20	.8
					- Spring	Rb 91	47	24	.96
					280 Muntz Metal-1/8 Hard	Rb 55	30	21	.84
					342-A High Leaded Brass-1/2 Hard	Rb 70	30.5	20	.8
					675 Manganese Bronze, A				
					- Soft Anneal	Rb 65	32.5	21	.84

Chart #4 Tons Pressure Required To Shear 1" Length

Metal Gauge	Mild Steel	Stainless Steel	Brass
20	1.01	1.50	.75
18	1.25	1.75	1.00
16	1.75	2.50	1.25
13	2.50	3.50	2.00
11	3.25	4.75	2.25
3/16"	4.25	7.00	3.25
1/4"	6.25	9.50	4.50
5/16"	8.00	12.00	5.50
3/8"	9.50	14.25	6.25
7/16"	11.00	16.50	7.75
1/2"	12.50	18.75	8.75
5/8"	15.75	23.50	11.00
3/4"	18.75	28.25	13.25
7/8"	22.00	33.00	15.50
1"	25.00	37.50	17.50

Chart #5 Clearances For Mild Steel

Gauge or Size	Approx. Decimal Thickness	Overall Clearance— Add To Punch Size
30	.0120	Slip Fit
28	.0149	Slip Fit
26	.0179	Slip Fit
24	.0239	.003
22	.0299	.003
20	.0359	.004
18	.0478	.005
16	.0598	.005
14	.0747	.006
13	.0897	.009
12	.1046	.009
11	.1196	.011
1/8	.125	.011
10	.1345	.013
5/32	.156	.015
8	.164	.017
7	.1793	.021
3/16	.1875	.023
1/4	.250	.031
5/16	.3125	.047
3/8	.375	.057
1/2	.500	.075
5/8	.625	.125
3/4	.750	.150

NOTE—Most grades of half hard aluminum use the same clearance as shown above. In many cases, your own experience may dictate that you call for clearances different than the above, especially when punching other materials such as stainless steel. Special clearances may be ordered for that purpose.

LIMITED WARRANTY

All new Roper Whitney tools and machines are warranted, to the original purchaser for use, to be free of defects in material and workmanship for a period of one year from purchaser's date of purchase. Roper Whitney Co. at its option will repair or replace, or refund the purchase price of, any tool or machine which fails within the warranty period and is found upon examination by Roper Whitney to be defective in material or workmanship, or both. This warranty does not cover failures attributable to improper use or maintenance, exceeding rated capacity, alteration, accident, or normal wear of moving parts. Accessories, controls, and hydraulic components not manufactured by Roper Whitney Co. are excluded from this warranty. For services on such parts, refer to applicable manufacturer's warranty.

Purchaser must give written notice to Roper Whitney Co. at the address shown below of any warranty claim within thirty days after failure, and if so instructed, return to Roper Whitney Co. the parts to be replaced or repaired, with all transportation charges prepaid by purchaser. Replacement parts will be invoiced to purchaser, with credit issued for parts covered by this warranty and freight thereon. Removal and reinstallation of replacement parts shall be at the purchaser's expense.

THERE IS NO OTHER EXPRESS WARRANTY TO THE EXTENT PERMITTED BY LAW.

ORDERING INFORMATION

TERMS: All prices net, f.o.b. factory.

WEIGHTS: All weights listed are shipping weights.

ORDERING CHANGES: No purchase order changes will be allowed after order has been processed by our order entry department except to correct an address or to cancel the order. If changes are necessary, a new purchase order must be entered.

CLAIMS: All claims for shortages must be made within 10 days of invoice date.

QUOTATIONS: Phone quotations are effective only if confirmed prior to shipment. All quotations must be in writing and are effective 30 days only.

ORDERING RULES: BEFORE PLACING AN ORDER, BE SURE TO OBSERVE FOLLOWING RULES TO SAVE TIME AND COST OF PHONE CALLS OR CORRESPONDENCE.

PUNCHING TOOLS . . . (1) Thickness of material. (2) Type of material. (3) Location of hole in material.

SHEARING TOOLS . . . (1) Thickness of material. (2) Width of material. (3) Length of material. (4) Type of material.

PUNCHES OR DIES . . . (1) Thickness of material. (2) Type of material. (3) Tool to be used.

PARTS . . . The model number and serial number of the machine or tool.

SHIPPING INSTRUCTIONS . . . Be sure to advise method of shipping. All orders will be shipped UPS, Parcel Post or Motor Freight unless otherwise indicated.

RETURN MERCHANDISE POLICY: The following is Roper Whitney Co. policy on merchandise returned.

(1) Merchandise returned will not be accepted without written authorization.

(2) Merchandise will not be accepted if the merchandise is not properly packed.

(3) Credit will not be allowed on merchandise that has been used or has been damaged as outlined in our Standard Warranty and subject to our inspection.

(4) All shipments to Roper Whitney Co. must be shipped prepaid unless prior written authorization has been issued.

(5) A restocking charge will be assessed on returned goods.

(6) Tools and machines returned to the factory for repairs will not be accepted unless formal purchase order accompanies or precedes tool or machine. If the tool or machine will require extensive repairs, the factory will notify the customer of the approximate cost of such repairs.

Authorization for the repairs must be received by the factory before the necessary repairs will be made. Minor repairs will be made by the factory without notification to the customer.

Units considered unreparable by the factory will be scrapped within 30 days unless return is requested in advance.

INCLUDING MERCHANTABILITY AND FITNESS FOR PARTICULAR PURPOSE, ARE EXCLUDED; AND IMPLIED WARRANTIES NOT EXCLUDED ARE LIMITED IN DURATION TO ONE YEAR FROM DATE OF PURCHASE. INCIDENTAL AND CONSEQUENTIAL DAMAGES ARE EXPRESSLY EXCLUDED FROM THE REMEDIES AVAILABLE TO PURCHASER, AND THE REMEDIES PROVIDED IN THIS WARRANTY SHALL BE EXCLUSIVE TO THE EXTENT PERMITTED BY LAW.

(NOTE: Some states do not allow limitations on how long an implied warranty lasts or the exclusion or limitation of incidental or consequential damages, so the foregoing limitations and exclusions may not apply to you. This warranty gives you specific legal rights, and you may also have other rights which vary from state to state.)

RETURN OF THE WARRANTY REGISTRATION CARD FURNISHED WITH THE PRODUCT PURCHASED IS NECESSARY TO OBTAIN WARRANTY COVERAGE THEREON. CARD MUST BE FULLY COMPLETED, SIGNED BY THE PURCHASER, AND IF APPLICABLE, SIGNED BY THE DISTRIBUTOR. RETURN REGISTRATION CARD TO:

ROPER WHITNEY OF ROCKFORD, INC.
2833 Huffman Boulevard
Rockford, Illinois 61101